



HONEY BEE KING II INSTRUCTION MANUAL

[Http://www.twf-sz.com](http://www.twf-sz.com)

EK1H-E016 / EK1H-E017

规格配备:

机身长: 535mm
 机身高: 225mm
 主旋翼直径: Φ 600mm
 尾旋翼直径: Φ 130mm
 马达齿轮: 9T
 主齿传动轮: 140T
 齿轮传动比: 9:140
 整机重: 约470g(含1000mAh、11.1V锂电)

动力及电子设备规格:

锂电池: 1000mAh、11.1V锂电池
 强磁马达: 370
 陀螺仪: 1Pcs
 伺服器: 8g*4Pcs
 发射机: 6通道或6通道以上(直升机系统)
 接收机: 6通道或6通道以上

EK1H-E018

电子配备:
 马达: 400无刷马达 锂电池: 11.1v 1500mAh锂电池
 发射机: 6通道或6通道以上(直升机系统)
 接收机: 6通道或6通道以上
 陀螺仪: ESKY尾传动直升机专用陀螺仪
 伺服器: 8g*4 Purchase 调速器: 25A无刷调速器

Specification:

Length: 535mm
 Height: 225mm
 Main blade diameter: Φ 600mm
 Tail blade diameter: Φ 130mm
 Motor gear: 9T
 Main driven gear: 140T
 Driven gear rate: 9:140
 Weight: About 470g(With 1000mAh、11.1V Li-Polymer battery)

Recommended Power and Radio Equipment:

Lithium Battery: 1000mAh、11.1V Li-Polymer battery
 Super motor: 370
 Gyro: 1Pcs
 Servo: 8g*4Pcs
 Transmitter: 6channel or more(Helicopter system)
 Receiver: 6channel or more

Power and Radio Equipment:

Lithium Battery: 1500mAh、11.1V;
 Power system: 400 Brushless super motor
 Transmitter: 6 channel or more(helicopter system);
 Receiver: 6 channel or more;
 Gyro: ESKY Professional gyro;
 Servo: 8g*4Pcs; Speed controller: Brushless ESC 25A

目录	Contents
----	----------

简介 Brief introduction	2
注意事项 Warning	2-3
飞行前的检查和调整 Pre-flight inspection and adjustment	4
电池的充电 Charging the battery pack	5-6
发射机介绍 Introduction of transmitter	6-8
起飞步骤 Flying process	9
直升机双桨的调整 Blade tracking adjustment	10
电子备料与连接方法 Electronic components and connection	11-12
单功能控制系统的调整 Adjustment of the monofunctional control system	13-14
尾伺服器的调整 Adjustment of tail servo	14
可变螺距控制系统是怎样运作的 How Does CCPM work	15
稳定翼组装步骤 Assembly process of paddles	16
主旋翼组组装步骤 Main rotor blade installation	17-18
主体侧板与动力系统组装步骤 Assembly process of main frame and power system	19-22
尾旋翼组组装步骤 Assembly process of tail rotor blades	23-24
分解图 Exploded view	25-26
装配完成图 Picture of completed assembly	27
配件图 Spare parts list	28-30
升级件 Upgraded parts list	31-32
一般保养方法 Regular maintenance	33-34
升级件的安装 Assembly process of upgraded parts	35-40
I. 主旋翼安装步骤 Assembly step for main blades	35-36
II. 尾旋翼安装步骤 Assembly step for tail rotor blades	36-37
III. 机身安装步骤 Assembly step for body	37-38
IV. 电子组装步骤 Assembly step for electronic parts	39-40

◆ **简介**

Brief introduction

感谢您选择ESKY产品,为了您更加了解使用这款直升机,请您仔细阅读本产品所配备的说明书后再进行组装以及操作这台直升机,并请您妥善的保存好说明书,以便以后对直升机的调整或是维修做参考。这款直升机是由 TWF 自行研发的新产品,无论您是初学者还是飞行爱好者都将是您的最佳选择。

Thank you for choosing ESKY products. Please read the manual carefully before assembling and operating the helicopter so as to know more about it. Be sure to keep the manual properly for future reference of adjustment or maintenance. This helicopter is a new product designed and developed by TWF. It would be your best choice, no matter you are a beginner or a heli fan.

◆ **注意事项**

Warning

遥控模型不是玩具,会对人身造成伤害,在操作之前请仔细阅读该手册,在操作中不要接近人群,防止伤害他人,注意自身安全. 电池充电远离易燃物品. 禁止14岁以下儿童操作. 造成事故本公司不负任何责任.

ESKY RC model helicopter is not a toy, Please read the instructions carefully before operation, it will cause serious bodily harm if misused. Please keep away from crowd when you are operating it. Please keep the battery away from combustible when charging. This RC Helicopter is not suitable for children under 14 years old, we will not be responsible for the accident.



警告
Warning

该符号表示你和他人需特别小心的地方,以免造成伤害!

The sign indicates things you and others should pay attention to, for fear the injury.



禁止
Prohibition

该符号表示为避免造成伤害的意外事故不允许的行为!

The sign indicates the unallowed actions that may cause incidence or damage.



1. R/C 模型直升机并不是玩具, 操作失误会造成人身伤害和损坏。
 2. 如果您是新手, 我们建议您找一位专业的或者操作熟练的模型爱好者指导您操作飞行。
 3. 在您操控模型之前您需要学习如何操控和检查所有控制系统是否正常, 然后再开始操控。
1. R/C model is not a toy! Incorrect operation may cause serious injury or damage.
 2. If you are a novice pilot we strongly suggest that you should find an experienced pilot in R/C model to assist you.
 3. It is absolutely necessary to read the manual of the helicopter before operation. It is mandatory to check all control systems and mechanical linkages for proper operation before every flight. Safety first!

It's not a toy!





直升机飞行速度极快，相对潜在一定的危险性，所以场地的选择也十分重要。

Since the helicopter flies very fast, it may cause potential danger, so the choice of the flight field is of great importance.



飞行时须选择四周没有人，无高压电线，少树木等的环境，避免操控不当造成自己与他人的安全及财产损失。

Do not fly near crowd, high voltage cables or trees to ensure the safety of yourself and others.



请勿在下雨，打雷等恶劣的气候下操作，以确保自身的安全。

Do not fly in the bad weather such as rainy or thundering to ensure the safety of yourself.



初学者建议在空旷场地飞行，并可适当搭配练习架练习飞行，这样能够很大程度的保护飞机，降低飞行失误所造成的损坏。

It is suggested to fly at an open field for beginners, and fly with the training set to practice yourself. In this case can the helicopter be protected and damage caused by the improper operation can be reduced.



在飞行场地或其附近飞行之前，需确认是否有相同频率的飞行物正进行飞行，否则将导致干扰。

Before flying, please make sure that no one else is operating on the same frequency, otherwise there will be the interference.



初学者飞行操控技巧在初期有一定的难度，要尽量避免独自操控飞行，最好请有经验的飞行员在旁指导。

It is difficult for beginners to fly skillfully at the first time, so you'd better fly under the guidance of the experienced pilot.



当直升机主旋翼与尾旋翼运转时，切勿触摸并且使直升机远离其他物件，以避免造成危险和损害。

Don't touch the helicopter when the main blade and tail blade were running, keep it away from other things to avoid danger and damage.



一般，由于遥控飞机是以PVC或聚乙烯为主要材料，所以尽量远离热源，避免因高温造成变形甚至发生熔毁的可能。

Generally, R/C models are mainly made up of PVC or polythene, please put it away from the heat source to avoid distortion and melting caused by high temperature.



飞行前的检查和调整 Pre-flight inspection and adjustment



在打开发射机之前,您需要确认油门操纵杆是否在最低点,油门微调是否在最低,然后检查倒置开关是否关闭,确认后再打开发射机的电源。
Be sure the throttle stick and the throttle trimmer are at the lowest position, and then check whether the reversing switch is pulled back before turning on the transmitter.



注意所有模型产品的遥控系统的开启都是先打开发射机再接通模型的电源,如果操做反了,可能会有危险。

Always turn on the transmitter first, and then power on the helicopter. If operated contrary, it may cause danger and injury.



当您打开发射机,在接通直升机电源时,直升机电子系统都需要进行自检,在正常情况下,陀螺仪指示灯(红灯)会快速闪烁,待红灯恒亮时,表示待飞状态,可以进行操作。

When you power on the transmitter and connect the battery, the helicopter will calibrate itself.

In the normal condition, the indicator light will flash continually. When red indicator gets constant light, it indicates ready to fly, you can operate then.



在自检过程中不要用手或其它方式让模型有任何移动。

Do not move the helicopter by hand or other ways when it is under self-calibration.



禁止在飞行时,用手去触摸。

It is prohibited to touch the model when flying.



禁止在人多场所飞行,以免失控至伤。

It is prohibited to fly at crowded place, otherwise it may be out of control and cause injury.



禁止在下雨天飞行。

It is prohibited to fly in the rainy days.



电池的充电 Charging the battery pack

- 1.将充电器与电源连接,此时充电器电源指示灯显示红灯,电源连接正常。
- 2.将需要充电的2节或3节锂聚合物电池分别(不可以同时)插入充电器绿色指示灯闪烁,表示正在充电。
- 3.待绿色指示灯停止闪烁时表示电池已经充满。
- 1.Connect the charger with power,then the red power indicator lights up,which indicates that the power connection is normal.
- 2.Connect the 2 cells or 3cells Li-polymer battery with charging ports of charger respectively or simultaneously, then the green charging indicator flashes and it indicates the battery is on charge.
- 3.Green indicator stops flashing shows that the battery is full.

警告: 充电时间最长不能超过120分钟

Warning: Charging time can not exceed 120 minute.

充电注意事项 Charging precautions

- 1.接通电源后,电源指示灯红灯会亮,红灯未亮表示电源没有连接好(图1)。
- 2.当电池连接好后,绿色指示灯会闪烁,表示正在充电。如果指示灯红灯和绿灯同时闪烁表示电池有误,请检查电池是否损坏。如果绿灯不亮,红灯闪烁时表示充电器进入保护状态,请断开充电器电源3秒以后重新接通电源。
- 3.充电完成后绿色指示灯恒亮,如果电池长时间不断开时,自放电使单节电池电压低于4.15V时充电器会重新给电池充电,直至再次充满,而且此过程会反复进行,确保电池为饱和状态。(图2)
- 4.充电时电池必须从模型上取下来进行充电。
- 5.锂聚合物电池在充电时必须有人看护。
- 6.充电器充电时应放在干燥通风处,远离热源,远离易燃易爆物品。
- 7.为了您更安全快捷的充电,请使用ESKY原厂出品的充电器。
- 1.After connecting the power,the red indicator would get light,otherwise,it indicates that power connection goes wrong.(fig 1)
- 2.Green indicator would flash after connecting the battery with charger,which indicates that battey is on charge. If green and red indicators flash simultaneously,it indicates the error with battery,please check whether the battery has been damaged.If green indicator goes out and red indicator flashes,it shows that the charger is under protection mode,please disconnect the power for 3 seconds and switch the power on again.
- 3.Green indicator gets constant light after the charge finished.If the battery has not been unplugged for a long time after charge finished,the battery would be recharged when single battery voltage is lower than 4.15V after self discharge.Also,this procedure will circulate,make sure the battery is in saturated state.(fig 2)
- 4.Take the battery out from the helicopter while charging.
- 5.Fire or serious injury would be resulted in under certain conditions,so please follow the instructions and never leave equipment unattended while charging.
- 6.Keep the battery charged in cool and ventilating place and be away from heat source,flammable and explosible materials.
- 7.To ensure secure and quick charging,please use ESKY original chargers.



电源指示灯
Power light

充电指示灯
Charge light



绿灯闪烁
The green indicator flashes



绿灯停止闪烁
The green indicator stop flashing

锂聚合物电池的充电方式(图示) Illustration of Li-po battery charging



发射机介绍 Introduction of transmitter

陀螺仪锁定开关
GYRO.SW

倒飞开关
IDEL

螺距行程直线微调
HOV.PIT

升降微调 (制式1)
Elevator trimmer(mode 1)
油门微调 (制式2)
Throttle trimmer(mode 2)

升降及副翼操作杆 (制式1)
Elevator(mode 1)/Aileron stick
油门及副翼操作杆 (制式2)
Throttle(mode 2)/Aileron stick

方向舵微调
Rudder trimmer

晶体
Crystal

伺服器倒置开关
Servo reversing switches

天线
Antenna

LED电压显示
LED Voltage indicator

教练开关
Trainer switch

螺距行程曲线微调
HOV.PIT

油门微调 (制式1)
Throttle trimmer(mode 1)
升降微调 (制式2)
Elevator trimmer(mode 2)

油门及副翼操作杆 (制式1)
Throttle(mode 1)/Aileron stick
升降及副翼操作杆 (制式2)
Elevator(mode 2)/Aileron stick

副翼微调
Aileron trimmer

电源开关向上打开电源
Push the power switch to the upper position to turn on the power.



制式1 (右手油门)
Mode 1(Right throttle)



当油门操作杆向上推动时, 直升机上升,
When the throttle stick is pushed forward, the
helicopter lifts up.



当油门操作杆向下推动时, 直升机下降。
When the throttle stick is pushed downward, the
helicopter descends.



当副翼操作杆向左移动时, 直升机飞向左边,
When the aileron stick is moved to the left,
the helicopter moves to the left.



当副翼操作杆向右移动时, 直升机飞向右边。
When the aileron stick is moved to the right,
the helicopter moves to the right.



当升降操作杆向上推动时, 直升机向前飞。
When the elevator stick is pushed forward, the
helicopter flies forward.



当升降操作杆向下推动时, 直升机向后飞。
When the elevator stick is pushed downward, the
helicopter flies backward.



当方向操作杆向左推动时, 直升机机头向左转,
When the rudder stick is moved to the left,
the head of helicopter moves to the left.



当方向操作杆向右推动时, 直升机机头向右转,
When the rudder stick is moved to the right,
the head of helicopter moves to the right.

制式2 (左手油门) Mode 2 (Left throttle)



当油门操作杆向上推动时, 直升机上升,
When the throttle stick is pushed forward, the helicopter lifts up.



当油门操作杆向下推动时, 直升机下降。
When the throttle stick is pushed downward, the helicopter descends.



当副翼操作杆向左移动时, 直升机飞向左边,
the helicopter moves to the left.



当副翼操作杆向右移动时, 直升机飞向右边。
When the aileron stick is moved to the right, the helicopter moves to the right.



当升降操作杆向上推动时, 直升机向前飞。
When the elevator stick is pushed forward, the helicopter flies forward.



当升降操作杆向下推动时, 直升机向后飞。
When the elevator stick is pushed downward, the helicopter flies backward.



当方向操作杆向左推动时, 直升机机头向左转,
the head of helicopter moves to the left.



当方向操作杆向右推动时, 直升机机头向右转,
the head of helicopter moves to the right.

起飞步骤 Flying process

Step1



1. Draw out the antenna of transmitter completely.
完全抽出发射机天线。

Step2



2. Turn on the transmitter and set the throttle stick and trimmer to the lowest position.
打开发射机,将油门操作杆微调设置为最低。

⚠注意:其他微调定位在中心点,检查所有倒置开关设置(如图)

Note: All the other trimmers must be set in center position, check all the setting of reversing switches as below.



关闭倒飞开关(开关往后为关闭状态)
Move the switch backwards to turn off the inverted flight switch



伺服器倒置开关设置(左手)
Setting of servo Reverser (left hand)



伺服器倒置开关设置(右手)
Setting of servo Reverser (right hand)

Step3



3. 将3mm胶,粘在电池上。
Stick the 3mm pastern to the battery.

Step4

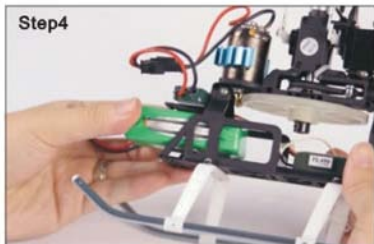

4. 将电池放入电池架上固定好。
Fix the battery on the battery holder.

Step5



5. 接通直升机电源之后,调速器会连续发出三声Bi Bi Bi的声音。
Power on the helicopter, the ESC will tone with BiBiBi.

Step6



6. 陀螺仪指示灯闪烁大约13秒左右,恒亮红灯表示正常待飞。
Gyro indicator will twinkle for appro 13 seconds, steady red indicates ready to fly

直升机双桨的调整 Blade tracking adjustment

直升机的双桨现象是一个普遍存在的现象，要想使您的直升机飞行稳定，首先要懂得如何处理双桨的问题，直升机的双桨现象是因为同一个平面旋转的不同主旋翼的攻角大小不一样导致不同的主旋翼不能在同一平面旋转，这种现象会引起机体振动，升力减少。

Flying helicopters, it is very necessary to track the main blade properly. We should adjust blades tracking as they are required so as to achieve a stable flight. If the angle of attack of the two rotor blades are not the same, the blades do not track in the same line, there will be a consequent vibration and decrease in lift.

木制主旋翼变形的影响很小，往往是因为翼形的误差，控制机构的间隙，结构塑料件的变形误差而导致双桨现象，如图所示

The influence of blade distortion with wood main rotor is small, the main reason that the wood main rotor blades are out of track are structure clearance, tolerance of the main rotor blades shape and the distorted plastic component, showing as below:

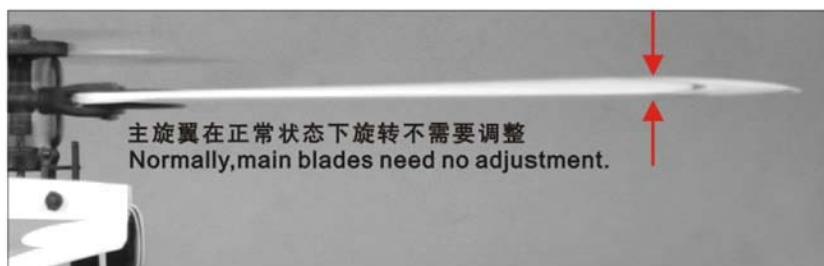
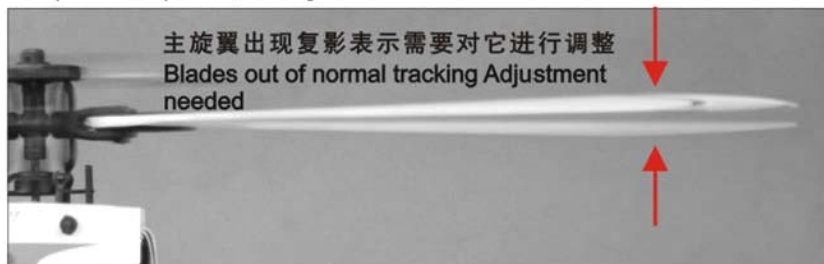

采用木制主旋翼的直升飞机都有攻角调整连杆，您只需扭转球座来改变攻角连杆的长度，就可轻而易举的完成双桨的调整，当然在调整时最好采用正负攻角配合调整。

The helicopter with wood main rotor blade all have pitch control links. You only need to turn the control link to achieve the blade tracking adjustment. Certainly, the best way is to adjust both pitch control link at the same time.



当您调整一支主旋翼还不能改变双桨现象时您可以调整另一支主旋翼来配合调整，这样反复的调整直到您的直升机的主旋翼在同一平面旋转，您会发现您的直升机很稳定。

If you made small adjustment on one rotor blade, the main rotor blades are still out of track, you need to adjust another blade, and repeat the process to check the blade tracking and make adjustment until both blades run in track. With proper adjustment, the helicopter will fly stably and smoothly.

电子配料与连接方法 Electronic components and connection

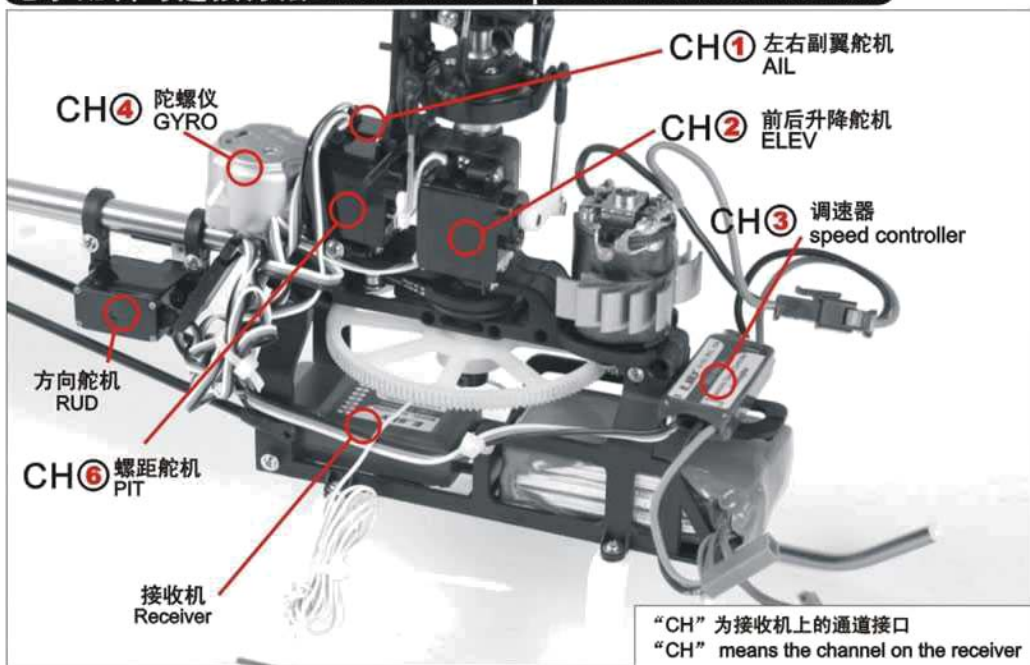

接收机的连接 Receiver Connection



陀螺仪的连接 Gyro connection



设备组装与调整 Assembly and adjustment of equipment

各部件与设备装配图示

Assembly diagram of each spare part and equipment:

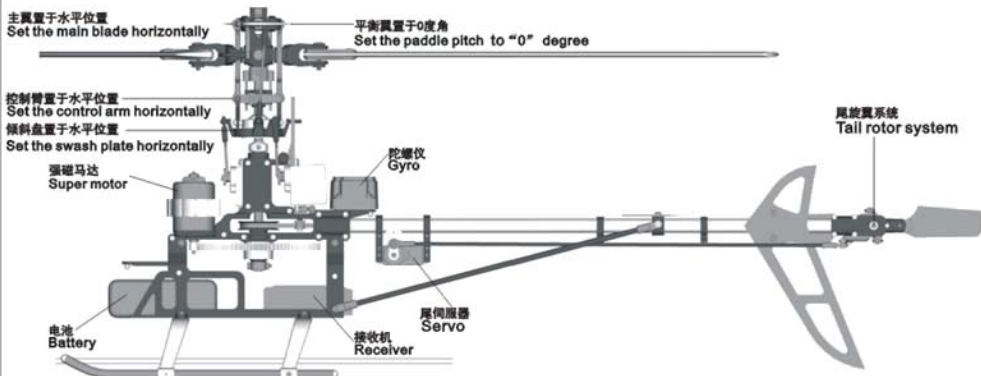

接收器、伺服器连接频道说明

Connection diagram of receiver and servo:

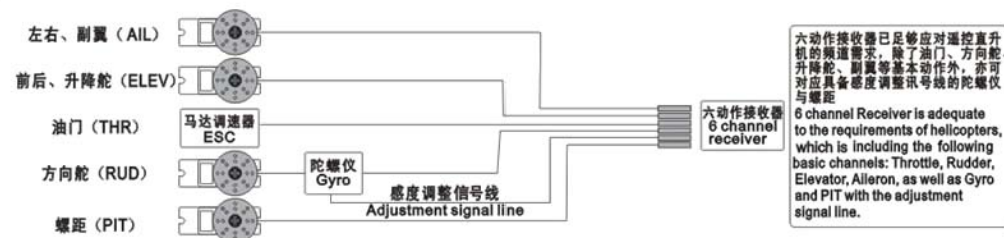

PITCH设定建议说明 飞行前主旋翼设定

Final pre-flight adjustment

Normal 一般飞行模式

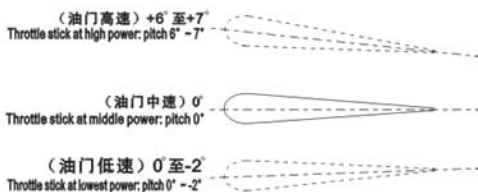

IDLE 特技飞行模式

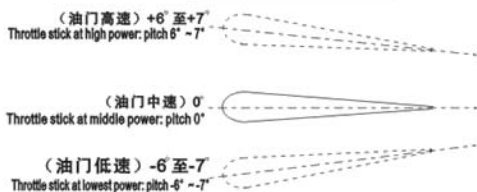

单功能控制系统的调整 Adjustment of the monofunction control system

因单功能控制系统主要应用于尾传动直升机。而尾传动直升机的主旋和尾旋的转速比是机械式固定的，所以只有对陀螺仪感度的调整。在直升机飞行时，主旋翼的转速与尾旋翼的转速是固定比例。如果发现尾部不受控制，一直左右小幅度颤抖，尾部无法居中且不受发射机控制时，那是因为尾部被锁得太紧，须调小陀螺仪感度。(如图1，图2)

The monofunctional helicopter control system mainly applies to helicopters with tail rotor driven system. As the rotation speed ratio of the main rotor blades and the tail rotor blades are automatically fixed, so only the adjustment of gain trimmer is needed. During the flight, the tail rotor blades and the main rotor blades rotate in a fixed proportion. If the tail is out of control not to get to the center position, and have a slight wobbling, which indicates that the tail is locked too tight, please adjust the gain trimmer to decrease(-) the gyro gain (fig.1 and fig.2)

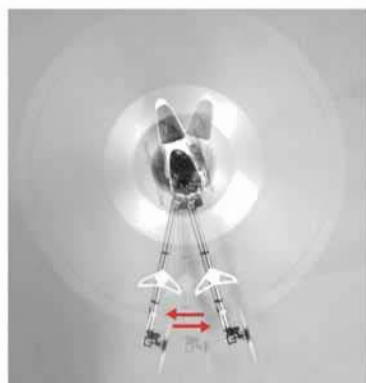

(图一 fig1)



(图二 fig2)

如果发现尾部一直在左右大幅度摇摆不定，尾部无法居中，且不受发射机控制时，这时要将陀螺仪上的感度调大，调到适当位置即可（如图3，图4）

If the tail is out of control and always keeping left-right wobbling violently, please adjust the Gain Trimmer to increase(+) the gyro gain (fig.3 and fig.4).

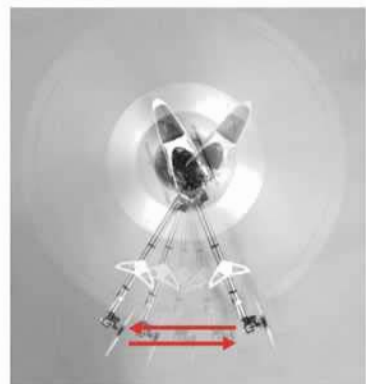

(图三 fig3)



(图四 fig4)



尾伺服器的调整 Adjustment of tail servo



由于直升机属于高精密模型，在直升机运转时，有多种情况可能引起直升机向一边转，可以参考以下方法调试，为避免以外发生，**建议把马达和调速器的接线断开**，打开发射机，将直升机接通电源。然后将发射机上方向操作杆和微调居中(图1)；保持尾伺服器连杆与尾管尽量平行(图2)，再配合尾伺服器座左右移动和尾旋翼横轴的距离(大约在横轴的3/1处)来调整(图3)，使尾伺服器和摆臂保持90度攻角(图4)

As the helicopter is high precision model, several circumstances may cause the helicopter rotates toward left or right, you can debug as below: Please disconnect brushless motor and ESC in order to avoid accident, turn on the transmitter and power on the helicopters. Then set rudder stick and trimmer centered (picture 1), keep tail servo link rod and tail tube parallel (picture 2), then adjust the tail servo mount and the distance to tail blade shaft (approximately in 1/3 position of the cross shaft) (picture 3), make the tail servo and servo horn at a 90° angle of attack (picture 4)

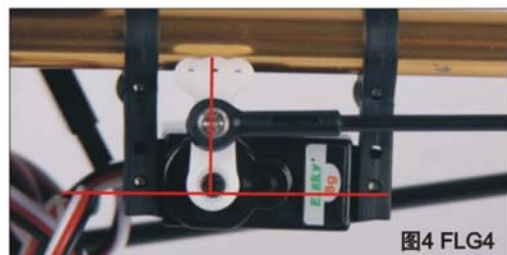
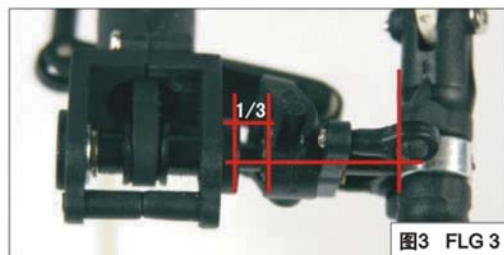

可变螺距是怎样运作的 The following pictures will show you how does CCPM work

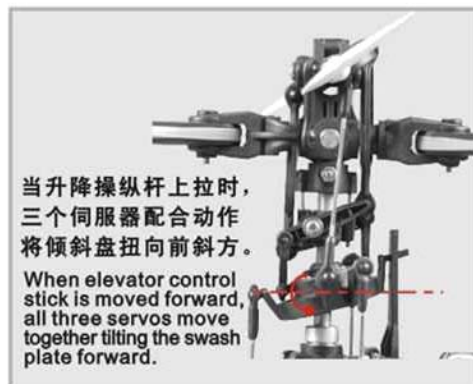
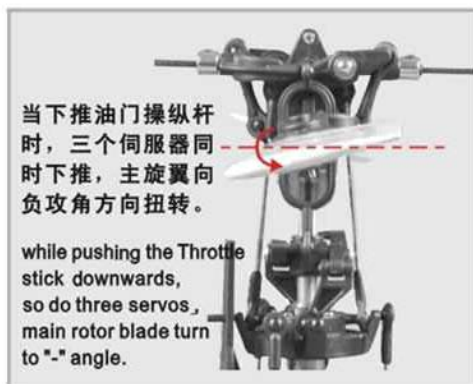
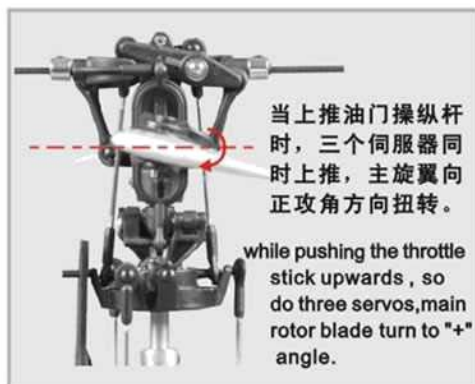

稳定翼组装步骤 Assembly process of paddles

零件用量表 Dosage form of spare parts

序号 NO	包装 Packing	品名 Name	数量 Quantity	规格 Specification	序号 NO	包装 Packing	品名 Name	数量 Quantity	规格 Specification	序号 NO	包装 Packing	品名 Name	数量 Quantity	规格 Specification
001	0286	平衡翼 Paddle	2		004	0284	平衡翼固定环 Paddle collar	2	Φ3*Φ7*5	007	0280	平衡杆限位件 Flybar spacing ring	1	
002	0286	平衡翼固定轴 Paddle fixed shaft	2		010	0284	贝尔臂铜套 Bell arm copper sheath	2	Φ3.4*Φ4*7.8	022	0302	MKP1703	2	M1.7*3
005	0301	MXH3003	4	M3*3	011	0302	TWP1704	2	T1.7*4	020	0213	滚珠轴承 Ball bearing	2	Φ3*Φ6*2.5
006	0284	平衡翼控制臂 Paddle control arm	2		013		垫片 Spacer	3	Φ2*Φ5*0.5	024	0302	TKP1704(大头) Large end screw	2	T1.7*4
015	0284	平衡杆中心座 Flybar center holder	1	Φ3*Φ6*L2.5	009	0284	贝尔控制臂 Bell control arm	2		003	0289	平衡翼杆	1	Φ1.8*200

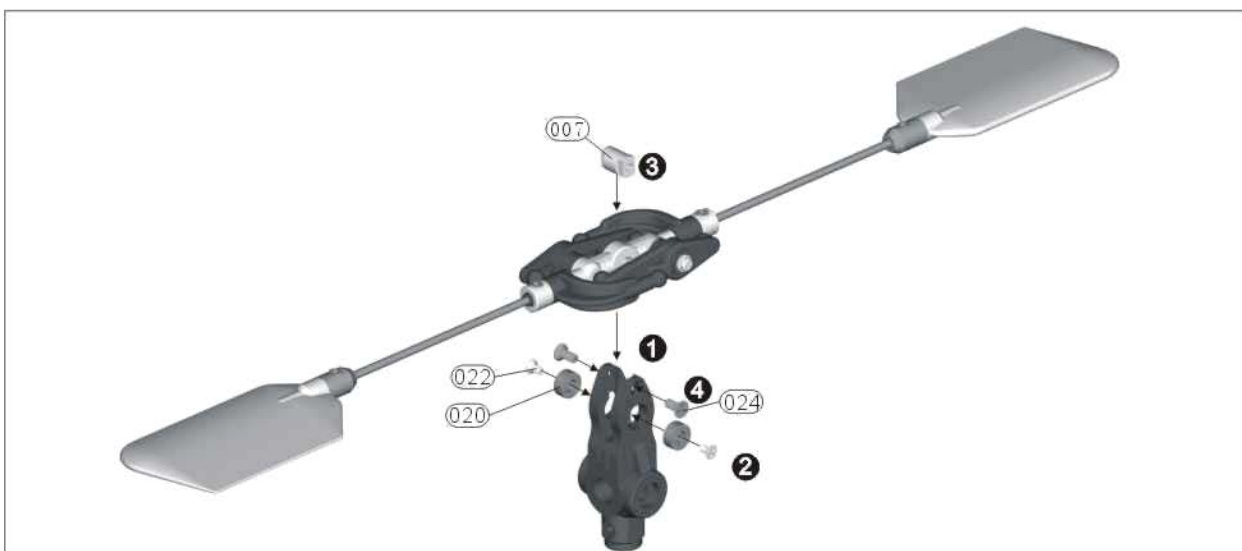
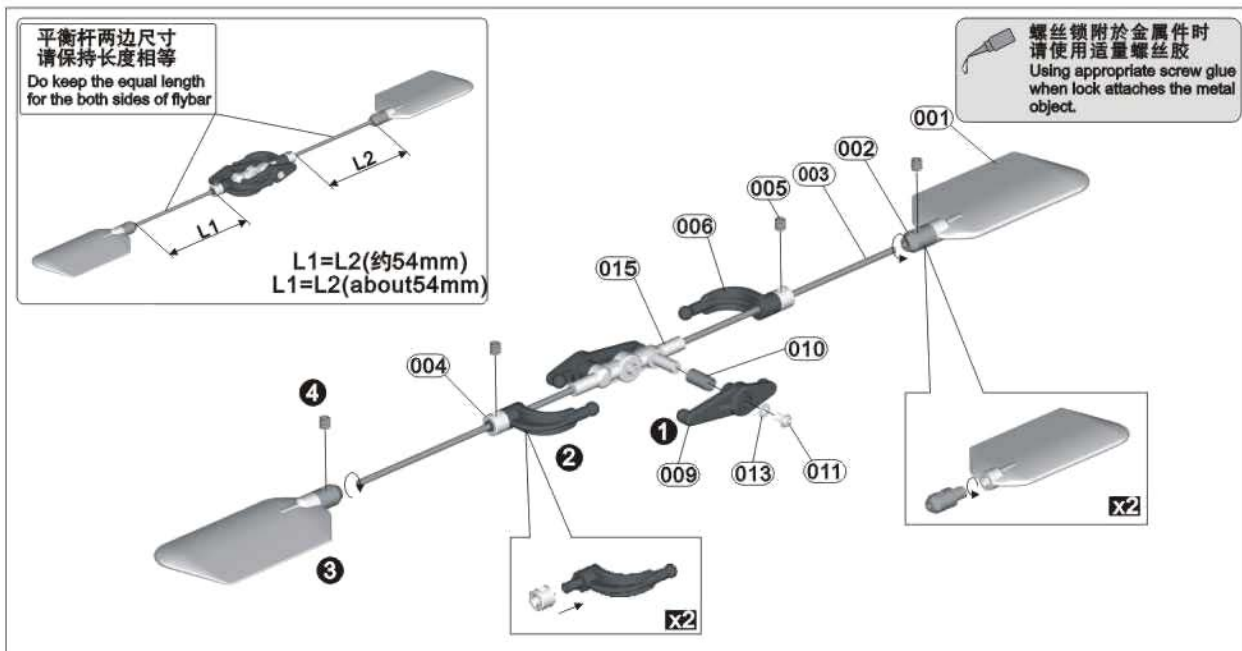

主旋翼组组装步骤 Main rotor blade installation

零件用量表 Dosage form of spare parts

序号 NO	包装 Packing	品名 Name	数量 Quantity	规格 Specification	序号 NO	包装 Packing	品名 Name	数量 Quantity	规格 Specification	序号 NO	包装 Packing	品名 Name	数量 Quantity	规格 Specification
031	0280	主翼特头固定塞 Fixed blade of center hub	1	Φ5.8*11	032	MHH2014		1	M2*14	038	0287	希拉控制臂内衬套 Rotor head control arm bush/liner	2	Φ3*Φ3.6*5
023	0280	主旋转头 Inner shaft	1		051	0565	主轴 Main shaft	1	Φ5*122	039	0287	希拉控制臂 Rotor head control arm	2	
030	0290	双孔拉杆 Ring-like push-rod	2		020	0213	滚珠轴承 Ball bearing	4	Φ3*Φ6*2.5	043	0283	希拉控制臂外衬套 Rotor head control arm	2	Φ3.6*Φ4.2*5
021	0280	O型圈 o-ring	2	Φ2*Φ6*2	028	0285	主翼夹头 Main blade clamp	2		037	0302	TWP2006	2	T2*6
026	0285	台阶垫片 Step washer	2	Φ3*Φ5.5*0.55	018		垫片 Spacer	2	Φ5*Φ8*0.2	045	0282	TKP1704(小头) Small end screw	4	T1.7*4
017	0301	防松螺母 Locknut	2	M3	029	0500	止推轴承 Thrust bearing	2	F3-8M	046	0282	倾斜内盖下盖 (后盖) Top cover of swashplate (rear)	1	
025	0344	主翼固定轴 Main blade fixed shaft	1	Φ3*46	044	0287	销子 Pin	2	Φ1.5*8	047	0282	万向球 Universal ball	1	SR5*8
036	0283	中心座 Center hub set	1		040	0287	剪型臂 Forcific arm	2		048	0282	倾斜外盖 Swashplate(outer)	1	
033	0283	相位插销 Phase pin	2	Φ1.2*20	042	0287	剪型臂衬套 Forcific arm bush	2	Φ1.5*2.5*4	050	0282	倾斜内盖下盖 (前盖) Bottom cover of swashplate (inner)	1	
035	0302	普通螺母 Nut	1	M2	034	0287	铜套 Copper sheath	1	Φ5*Φ6*10	049	0282	滚珠轴承 Ball bearing	1	Φ20*Φ27*4

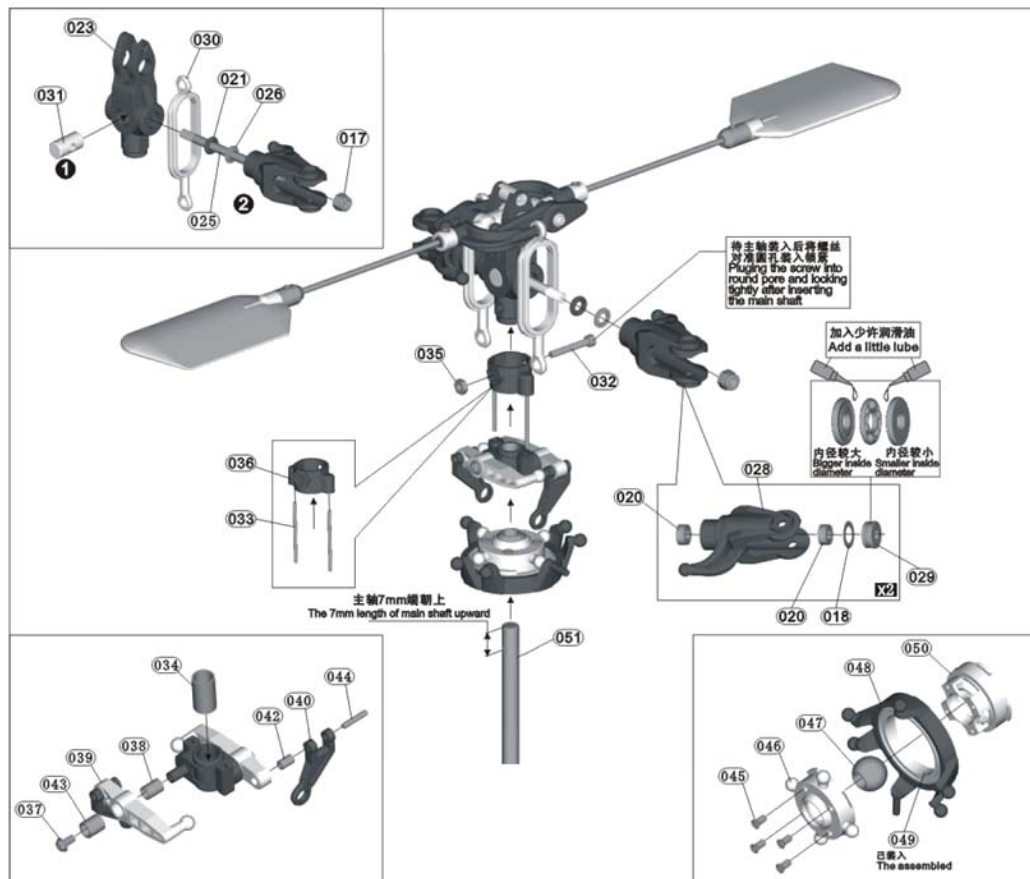

主旋翼组组装步骤 Main rotor blade installation

零件用量表 Dosage form of spare parts

序号 NO	包装 Packing	品名 Name	数量 Quantity	规格 Specification	序号 NO	包装 Packing	品名 Name	数量 Quantity	规格 Specification	序号 NO	包装 Packing	品名 Name	数量 Quantity	规格 Specification
016	0309	主翼 Main blade	2		069	0288	滚珠轴承 Ball bearing	2	$\phi 5 \times \phi 10 \times 3$	070	0303	主齿轮 Main gear	1	140T
019	0301	MHH2516	2	M2.5*16	063	0562	前同步皮带轮固定销 Cap of synchro belt pulley (69.12)	1	$\phi 1.5 \times 10$	072	0303	单向轴承座 One way bearing hold	1	
027	0301	普通螺母 Nut	2	M2.5	092	0564	皮带 Belt	1	380	071	0303	单向轴承 One-way bearing	1	$\phi 8 \times \phi 10 \times 12$
008	0290	双孔连杆 Ring-like linkage	2		123	0562	带轮隔套 Belt pulley cap	1	$\phi 5 \times \phi 6 \times 3.3$	074	0303	单向轴承连动轴 One way auto-driven shaft	1	$\phi 5 \times \phi 9 \times 17$
012	0290	拉杆头A Drawbar head A	7		014	0290	拉杆A Push link A	2	$\phi 1.4 \times 44$	024	0302	TKP1704(大头) Large end screw	3	T1.7*4
058	0290	拉杆B Push link B	3	$\phi 1.4 \times 29$	073	0301	MHH2012	1	M2*12	065	0562	前同步皮带轮盖 Cap of synchro belt pulley (front)	1	
061	0281	定位环 Set collar	1		035	0301	普通螺母 Nut	1	M2	064	0562	前同步皮带轮 Synchro belt pulley(front)	1	
005	0301	MXH3003	1	M3*3										

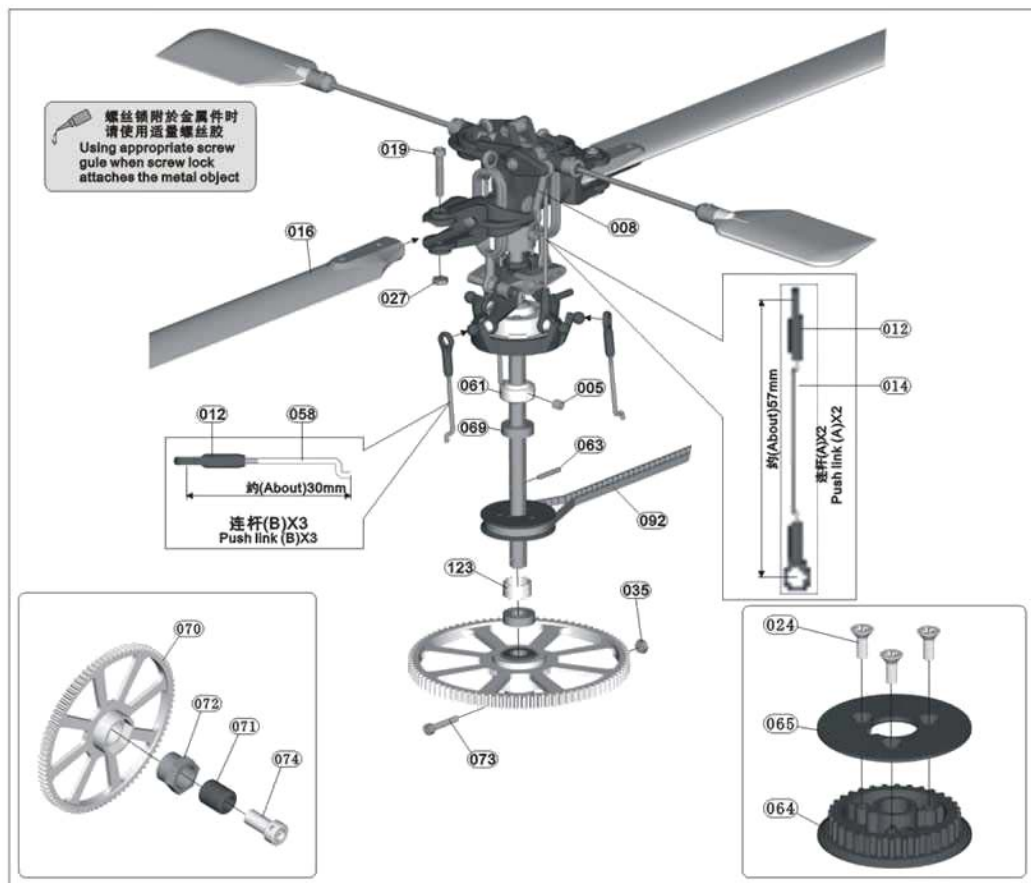

主体侧板与动力系统组装步骤 Assembly process of main frame and power system

零件用量表 Dosage form of spare parts

序号 NO	包装 Packing	品名 Name	数量 Quantity	规格 Specification	序号 NO	包装 Packing	品名 Name	数量 Quantity	规格 Specification	序号 NO	包装 Packing	品名 Name	数量 Quantity	规格 Specification
060	0558	右侧板 Right frame	1		067	0562	凸缘轴承 Flange bearing	2		076	0560	滑撬支架 Skid strut	2	
062	0337	机壳支撑杆 Cabin knighthead	1	Φ2*65	068	0562	TPP2008	2	T2*8.5	077	0560	滑撬杆 Skid bar	2	Φ5*155
081	0558	TPP1405	1	T1.4*5	037	0559	TWP2006	4	T2*6	078	0560	滑撬管塞头 Skid tube chock plug	4	
082	0558	TPP1709	13	T1.7*9	075	0559	电池架 Battery hanger set	1		121		天线套管 Antenna bushing	1	Φ3*230
066	0562	凸缘轴承盖 Flange bearing cover	2		045	0580	TKP1704(小头) Small end screw	2	T1.7*4					

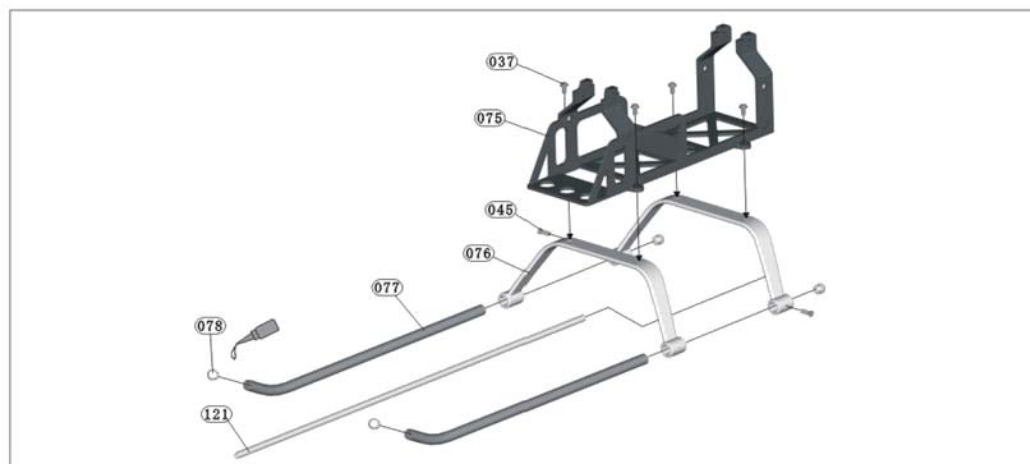
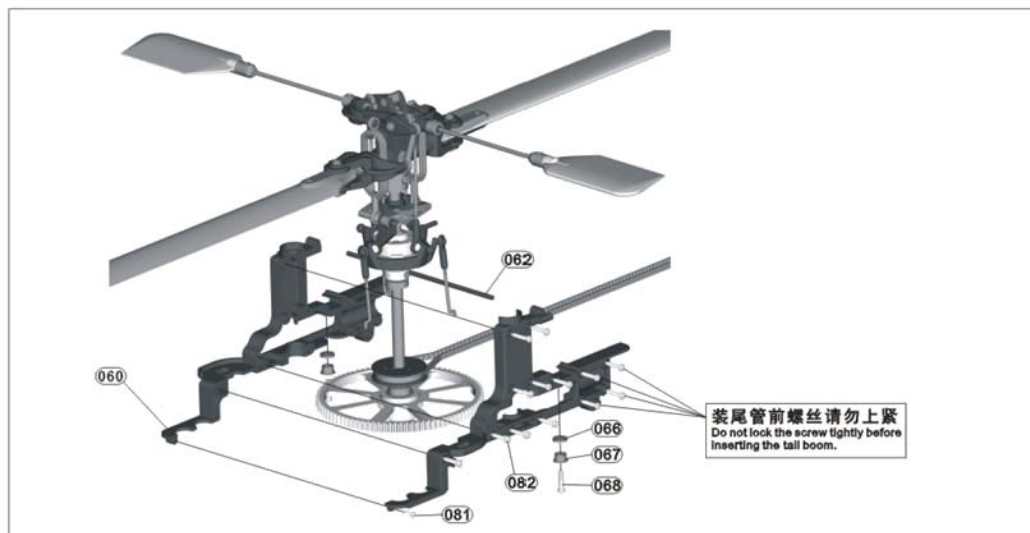

主体侧板与动力系统组装步骤 Assembly process main frame and power system

零件用量表 Quantity form of spare parts

序号 NO	包装 Packing	品名 Name	数量 Quantity	规格 Specification	序号 NO	包装 Packing	品名 Name	数量 Quantity	规格 Specification	序号 NO	包装 Packing	品名 Name	数量 Quantity	规格 Specification
052	0006	强磁马达 Super motor	1	370	053	0006	马达齿 Motor gear	1	9T	122		垫片 Spacer	2	Φ3.2*Φ7*0.5
119	0224	马达散热罩 Motor heat sink	1		124	0302	TWP1706	4	T 1.7*6	054		MPP3058	2	M3*5.8

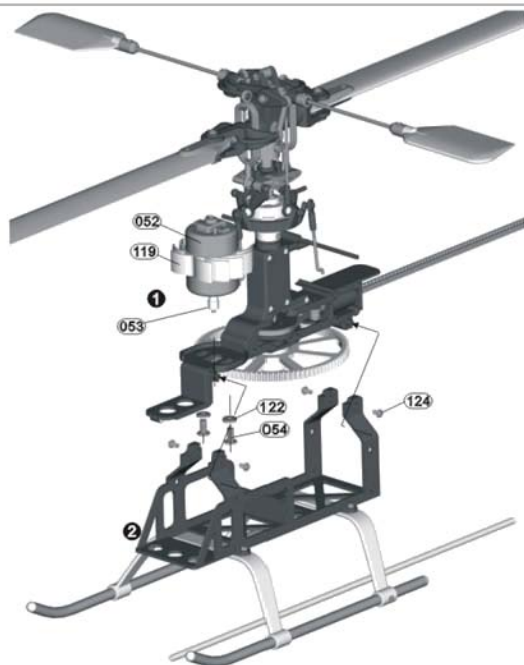

螺丝规格参照图 Screws specification



主体侧板与动力系统组装步骤 Assembly process main frame and power system

零件用量表 Dosage form of spare parts

序号 NO	包装 Packing	品名 Name	数量 Quantity	规格 Specification	序号 NO	包装 Packing	品名 Name	数量 Quantity	规格 Specification	序号 NO	包装 Packing	品名 Name	数量 Quantity	规格 Specification
087	0563	尾管 Tail boom	1	Φ8*317	097	0291	垂直翼 Vertical fin set	1		059	0500	伺服器 Servo	1	
091	0302	MPP2007	1	M2*7	055	0561	尾支撑杆头 Head of tail sustaining rod	4		086	0293	尾SERVO固定座 Tail servo control set	2	
011	0302	TWP1704	6	T1.7*4	056	0561	尾支撑杆 Tail sustaining rod	2	Φ3*180	094	0567	MKP2005	1	M2*6
090	0291	水平翼 Horizontal fin set	1		089	0291	水平垂直翼固定座 Horizontal fin control set	2		093	0567	铝球 Aluminium ball	1	Φ4*3
037	0302	TWP2006	4	T2*6	088	0291	导向环 Caudal ring	2						

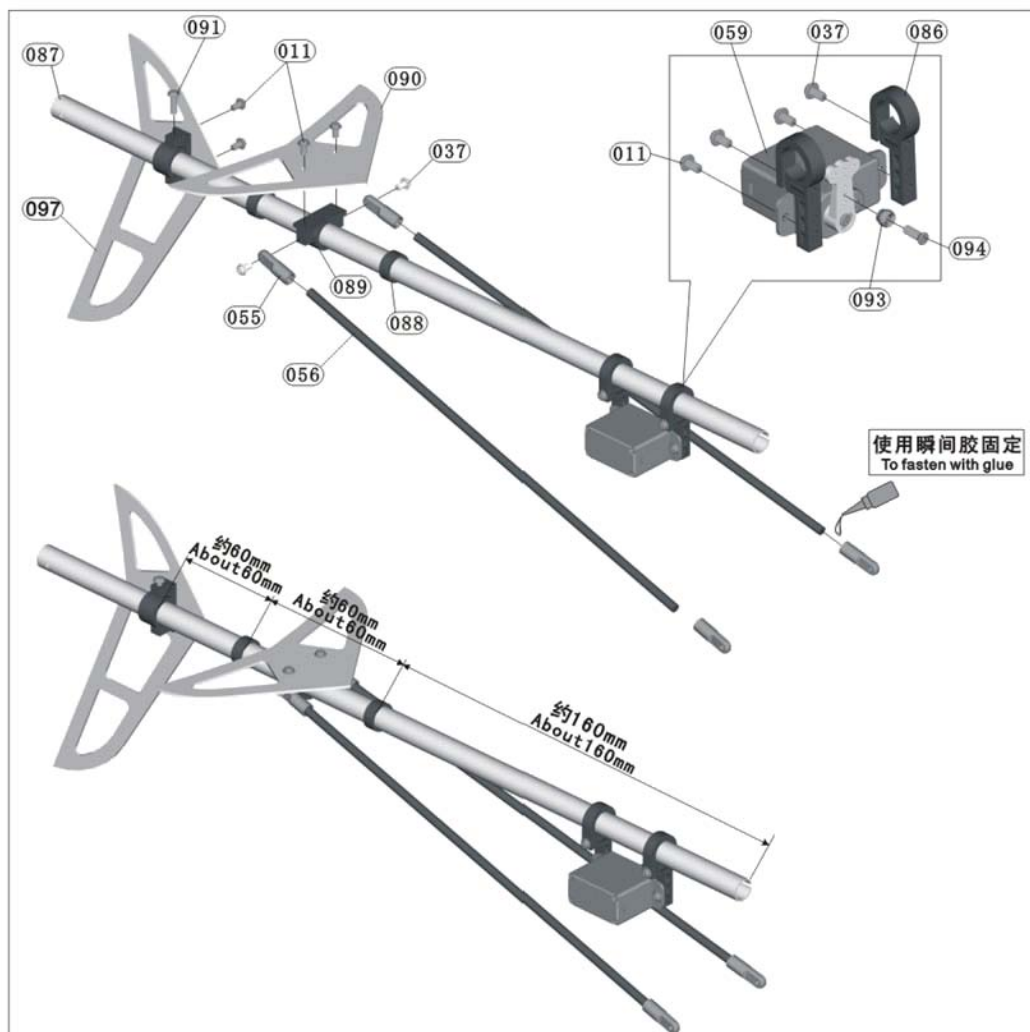

主体侧板与动力系统组装步骤 Assembly process main frame and power system

零件用量表 Dosage form of spare parts

序号 NO	包装 Packing	品名 Name	数量 Quantity	规格 Specification	序号 NO	包装 Packing	品名 Name	数量 Quantity	规格 Specification	序号 NO	包装 Packing	品名 Name	数量 Quantity	规格 Specification
087	0563	尾管 Tail boom	1	Φ8*317	097	0291	垂直翼 Vertical fin seat	1		059	0500	伺服器 Servo	1	
091	0302	MPP2007	1	M2*7	055	0561	尾支撑杆头 Head of tail sustaining rod	4		086	0293	尾SERVO固定座 Tail servo control set	2	
011	0302	TWP1704	6	T1.7*4	056	0561	尾支撑杆 Tail sustaining rod	2	Φ3*180	094	0567	MKP2005	1	M2*6
090	0291	水平翼 Horizontal fin set	1		089	0291	水平垂直翼固定座 Horizontal fin control set	2		093	0567	铝球 Aluminium ball	1	Φ4*3
037	0302	TWP2006	4	T2*6	088	0291	导向环 Caudal ring	2						

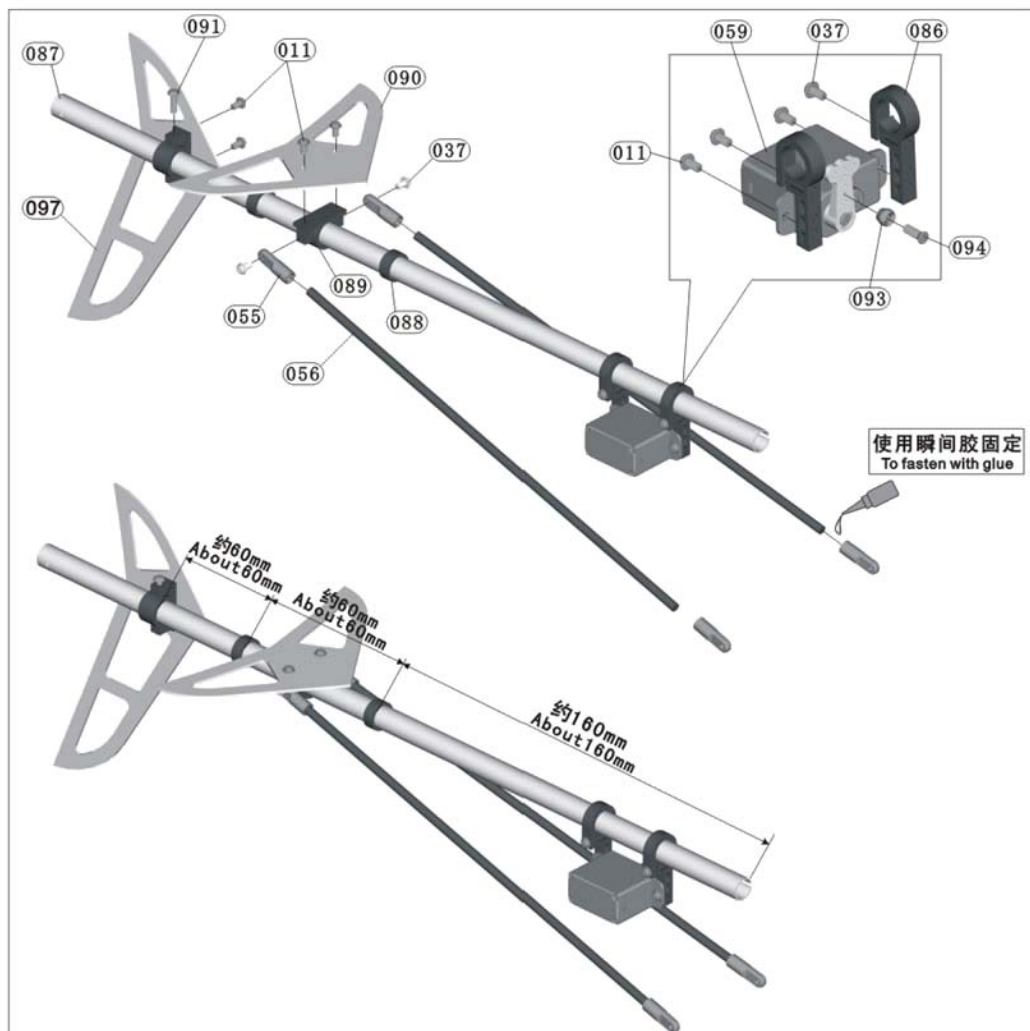

尾旋翼系统组装步骤 Tail rotor system installation

零件用量表 Dosage form of spare parts

序号 NO	包装 Packing	品名 Name	数量 Quantity	规格 Specification	序号 NO	包装 Packing	品名 Name	数量 Quantity	规格 Specification	序号 NO	包装 Packing	品名 Name	数量 Quantity	规格 Specification
037	0302	TWP2006	2	T2*6	101	0562	尾同步皮带轮 Tail synchro belt pulley	1		117	0302	MPP2010	2	M2*10
104	0292	尾牙箱右侧板 Tail gear box(right)	1		100	0568	滚珠轴承 Ball bearing	1	$\Phi 3^* \Phi 7^* 3$	115	0298	尾翼夹头 Tail rotor blade clamp	2	
103	0562	尾轴 Tail shaft	1	$\Phi 3^* 44$	081	0558	TPP1405	1	T1.4*5	116	0296	尾翼固定轴 Tail rotor blade fixed shaft	1	
026	0285	台阶垫片 Step spacer	2	$\Phi 3^* \Phi 5.5^* 0.55$	098	0302	TPP1407(大圆头) Truss head	4	T1.4*7	005	0301	MXH3003	1	M3*3
020	0213	滚珠轴承 Ball bearing	1	$\Phi 3^* \Phi 6^* 2.5$	113	0294	尾旋翼 Tail rotor blade	2		118	0218	滚珠轴承 Ball bearing	2	$\Phi 2^* \Phi 6^* 3$
102	0562	尾同步皮带轮盖 Cap of tail synchro belt pulley	1		114	0301	MHH2007	2	M2*7					

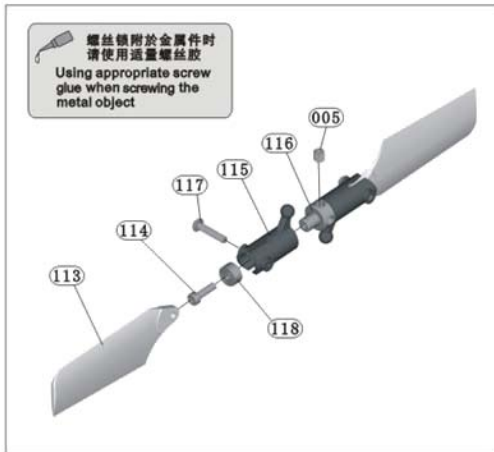
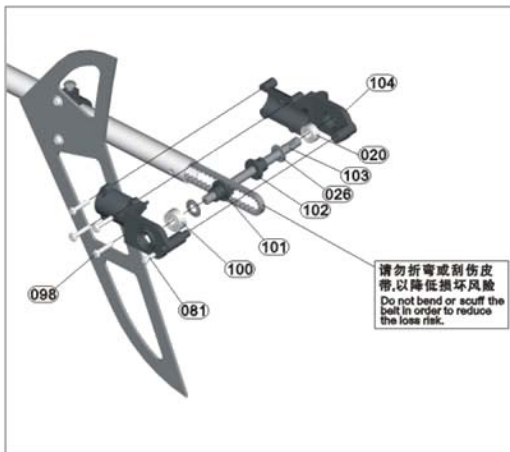

尾旋翼系统组装步骤 Tail rotor system installation

零件用量表 Quantity form spare parts

序号 NO	包装 Packing	品名 Name	数量 Quantity	规格 Specification	序号 NO	包装 Packing	品名 Name	数量 Quantity	规格 Specification	序号 NO	包装 Packing	品名 Name	数量 Quantity	规格 Specification
111	0298	拉杆头B Push-rod head B	2	Φ3*Φ6*L2.5	105	0292	尾旋翼内衬套 Tail rotor control arm bush(inner)	1	Φ3*Φ3.6*L3.6	079	0293	限位挡块 Spacing back plate	1	
110	0295	尾旋翼控制臂 Tail rotor blade control arm	1		106	0295	尾旋翼外衬套 Tail rotor control arm bush(outer)	1	Φ3.6*Φ4.2*L3.6	037	0302	TWP2006	2	T2*6
081	0298	TPP1405	2	T.4*5	011	0302	TWP1704	7	T1.7*4	096	0567	尾拉杆 Tail push-rod	1	Φ2*254
093	0567	铝球 Aluminium ball	1	Φ4*3	057	0293	SERVO固定座(长) Servo mount(L)	2		095	0567	尾拉杆杆头 Tail push-rod head	2	
094	0567	MKP2005	1	M2*5	059	0500	伺服器 Servo	3	8g	083	0293	SERVO固定座(短) Servo fixed set (short)	2	
107	0298	尾摇臂 Tail rotor control arm	1											

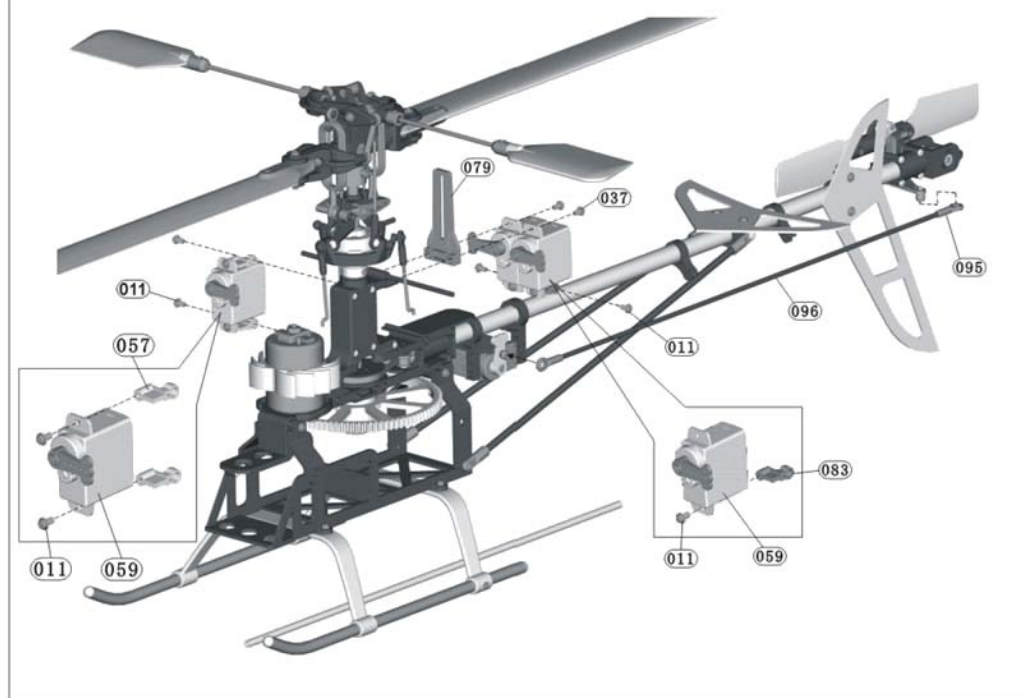
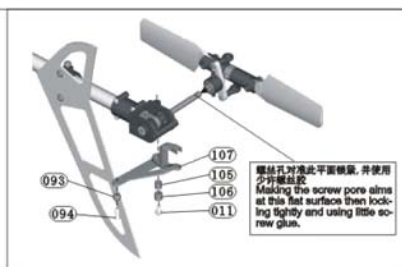
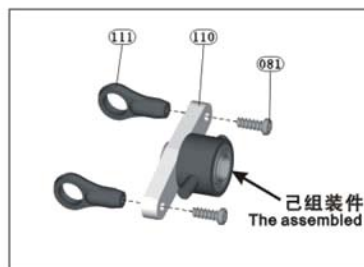

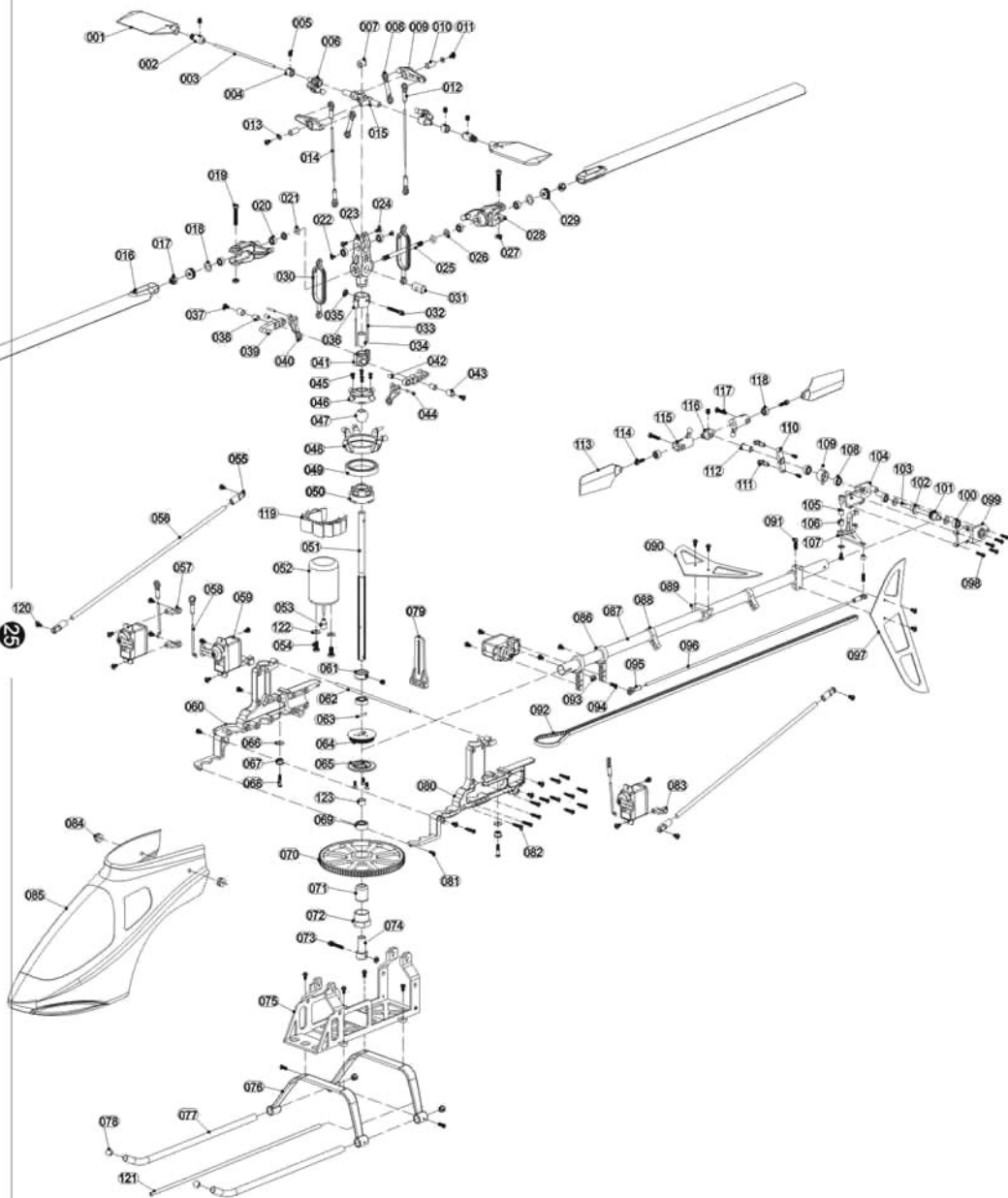

25

分解图 Explosion Picture

散件总览表 Exploded view

编号 NO	名称 Name	数量 Quantity	规格 Specification
001	平衡翼 Paddle	2	
002	平衡翼固定轴 Paddle fixed shaft	2	
003	平衡翼杆 Flybar	1	Ø1.8*200
004	平衡翼固定环 Paddle collar	2	Ø3*Ø7*5
005	MXH3003	6	M3*3
006	平衡翼控制臂 Paddle control arm	2	
007	平衡翼限位件 Flybar spacing ring	1	
008	双孔连杆 Ring-like push-rod	2	
009	贝尔控制臂 Bell control arm	2	
010	贝尔臂铜套 Bell arm copper sheath	2	Ø3.4*Ø4*7.8
011	TWP1704	17	T1.7*4
012	拉杆头 A Head of push link A	7	
013	垫片 Spacer	3	Ø2*Ø5*0.5
014	拉杆 A Push link A	2	Ø1.4*44
015	平衡杆中心座 Flybar center holder	1	
016	主翼 Main blade	2	
017	防松螺母 Locknut	2	M3
018	垫片 Spacer	2	Ø5*Ø8*0.2
019	MHH2516	2	M2.5*16
020	滚珠轴承 Ball bearing	7	Ø3*Ø6*2.5
021	0型圈 "o" ring	2	Ø2*Ø6*2
022	MKP1703	2	M1.7*3
023	主旋转头 Inner shaft	1	
024	TKP1704(大头) Large end screw	6	T1.7*4
025	主翼固定轴 Main blade fixed shaft	1	Ø3*465
026	台阶垫片 Step washer	4	Ø3*Ø5.5*0.5
027	普通螺母 Nut	2	M2.5
028	主翼夹头 Main blade clamp	2	
029	止推轴承 Thrust bearing	2	F3-8M
030	双孔拉杆 Ring-like push-rod	2	
031	主旋转头固定套 Fixed plug of center hub set	1	Ø5.8*11
032	MHH2014	1	M2*14
033	相位拨销 Phase pin	2	Ø1.2*20
034	铜套 Copper sheath	1	Ø6*Ø6*10
035	普通螺母 Nut	2	M2
036	中心座 Center hub set	1	
037	TWP2006	10	T2*6
038	希拉控制臂内衬套 Rotor head control arm bush (inner)	2	3*3*6.5
039	希拉控制臂 Rotor head control arm	2	
040	前翼臂 Fortifoform arm	2	
041	中心座滑块 Center holder block	2	

编号 NO	名称 Name	数量 Quantity	规格 Specification
042	前翼臂衬套 Fortifoform arm bush	2	1.5*2.5*4
043	希拉控制臂外衬套 Rotor head control arm bush(outer)	2	3*5*4.2
044	销子 Pin	2	1.5*8
045	TKP1704(小头) Small end screw	6	T1.7*4
046	倾斜内盘上盖 Top cover of swashplate(inner)	1	
047	万向球 Universal ball	1	SR5*8
048	倾斜外盘 Swashplate(outer)	1	
049	滚珠轴承 Ball bearing	1	Ø20*Ø27*4
050	倾斜内盘下盖 Bottom cover of swashplate (inner)	1	
051	主轴 Main shaft	1	Ø5*122
052	强磁马达 Super motor	1	370
053	马达齿 Motor gear	1	10T
054	MPP3058	2	M3*5.8
055	尾支撑杆头 Head of tail sustaining rod	4	
056	尾支撑杆 Tail sustaining rod	2	Ø3*180
057	SERVO固定座(长) Servo mount(L)	2	
058	拉杆B Push link B	3	Ø1.4*29
059	伺服器 Servo	3	89
060	右侧板 Right frame	1	
061	定位环 Collar	1	
062	机壳支撑杆 Cabin knighthead	1	Ø2*65
063	前同步皮带轮固定销 Cap of synchro belt pulley fixed pin	1	Ø1.5*10
064	前同步皮带轮 Synchro belt pulley(front)	1	Ø2*65
065	前同步皮带轮盖 Cap of synchro belt pulley	1	Ø2*65
066	凸缘轴承盖 Flange bearing cover	2	
067	凸缘轴承 Flange bearing	2	
068	TPP2008	2	Ø12*8.5
069	滚珠轴承 Ball bearing	2	Ø5*Ø10*3
070	主齿轮 Main gear	1	140T
071	单向轴承 One way bearing	1	Ø6*Ø10*12
072	单向轴承座 One way bearing hold	1	
073	MHH2012	1	M2*12
074	单向轴承连动轴 One way auto-driven shaft	1	Ø5*Ø9*17
075	电池架 Battery hanger set	1	
076	滑撬杆 Skid strut	2	Ø5*155
077	滑撬支架 Skid bar	1	
078	滑撬管塞头 Skid tube chock plug	4	
079	限位挡块 Spacing back plate	1	
080	左侧板 Left frame	1	
081	TPP1405	4	T1.4*5
082	TPP1709	13	T1.7*9

编号 NO	名称 Name	数量 Quantity	规格 Specification
083	SERVO固定座(短) Servo fixed set(short)	2	
084	软胶头 Soft colloid	2	
085	机头罩 Cabin	1	
086	SERVO尾翼固定座 Tail servo control set	2	
087	尾翼 Tail boom	1	6*Ø317
088	导向环 Caudal ring	2	
089	水平垂直翼固定座 Horizontal fin control set	2	
090	水平翼 Horizontal fin set	1	
091	MPP2007	1	M2*7
092	皮带 Belt	1	380
093	铝球 Aluminium ball	2	4Ø*3
094	MKP2005	2	M2*5
095	尾拉杆头 Tail push-rod head	2	
096	尾拉杆 Tail push-rod	1	Ø2*254
097	垂直翼 Vertical fin set	1	
098	TPP1407	4	T1.4*7
099	尾牙箱左侧板 Tail gear box(left)	1	
100	滚珠轴承 Ball bearing	1	Ø3*Ø7*3
101	尾同步皮带轮 Tail synchro belt pulley	1	
102	尾同步皮带轮盖 Cap of tail synchro belt pulley	1	
103	尾轴 Tail shaft	1	Ø3*44
104	尾牙箱右侧板 Tail gear box(right)	1	
105	尾翼臂内衬套 Tail rotor control arm bush(inner)	1	3*3.6*3.6
106	尾翼臂外衬套 Tail rotor control arm bush(outer)	1	3.6*4.2*3.6
107	尾翼臂 Tail rotor control arm	1	
108	滚珠轴承 Ball bearing	2	Ø4*7*2.5
109	轴承座 Bearing holder	1	
110	尾翼控制臂 Tail rotor blade control arm	1	
111	拉杆头B Push-rod Head B	2	
112	尾翼距俯控制座 Tail pitch control set	1	Ø4*Ø5*8.9
113	尾旋翼 Tail rotor blade	2	
114	MHH2007	2	M2*7
115	尾翼夹头 Tail rotor blade clamp	2	
116	尾翼固定轴 Tail rotor blade fixed shaft	1	
117	MPP2010	2	M2*10
118	滚珠轴承 Ball bearing	2	Ø2*Ø6*3
119	马达散热器 Motor heat sink	1	
120	TWP2004	2	T2*4
121	天线套管 Antenna bushing	1	3*Ø230
122	垫片 Spacer	2	Ø3.2*Ø7*0.5
123	带轮隔套 Belt pulley cap	1	Ø5*Ø6*3.3
124	TWP1706	4	T1.7*6

标准版装配完成图 Picture of fulfilled assembly

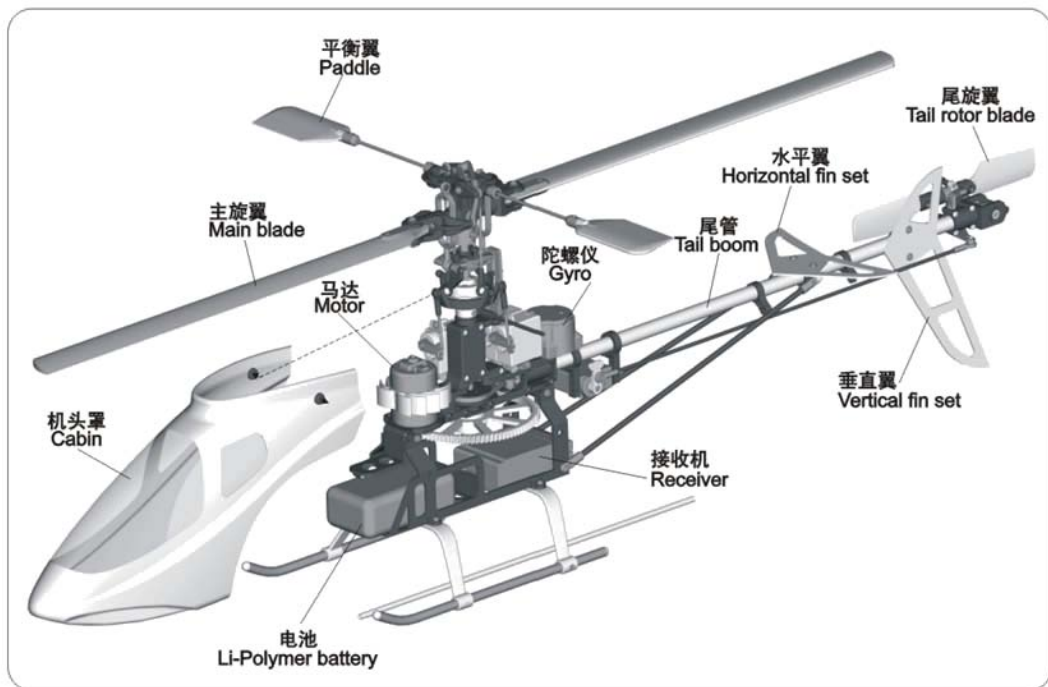

规格配备:

机身長: 535mm
 机身高: 225mm
 主旋翼直径: Φ 600mm
 尾旋翼直径: Φ 130mm
 马达齿轮: 9T
 主齿传动轮: 140T
 齿轮传动比: 9:140
 整机重: 约470g(含1000mAh、11.1V锂电)

动力及电子设备规格:

锂电池: 1000mAh、11.1V锂电池
 强磁马达: 370
 陀螺仪: 1Pcs
 伺服器: 8g*4Pcs
 发射机: 6通道或6通道以上(直升机系统)
 接收机: 6通道或6通道以上

Specification:

Length: 535mm
 Height: 225mm
 Main blade diameter: Φ 600mm
 Tail blade diameter: Φ 130mm
 Motor gear: 9T
 Main driven gear: 140T
 Driven gear rate: 9:140
 Weight: About 470g(With 1000mAh、11.1V Li-Polymer battery)

Recommended Power and Radio Equipment:

Lithium Battery: 1000mAh、11.1V Li-Polymer battery
 Super motor: 370
 Gyro: 1Pcs
 Servo: 8g*4Pcs
 Transmitter: 6channel or more(Helicopter system)
 Receiver: 6channel or more

“▲”表示Honey Bee King II 碳纤维版配件

“▲” indicates the carbon fibre spare parts of Honey Bee King II

整机配件图 Spare parts picture



Bearing
轴承



Center hub & spindle set
主旋转头套件



Bell control arm set
贝尔控制臂组



Rotor head control link set
希拉控制臂组

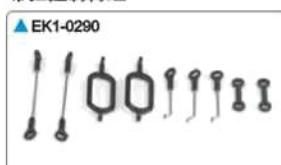

Push link set
连杆组套件

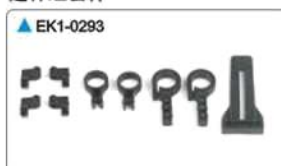

Servo controller
伺服器固定座组

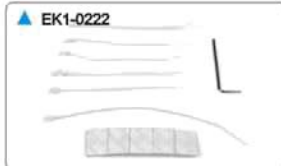

Allen Key
工具包



Swashplate set
倾斜盘套件



Main blade clamp set
主翼夹头组



Bearing
轴承



Vertical fin set
垂直水平尾翼组



Plastic tail blade (white)
塑胶尾旋翼(白色)



Main motor heat-sink
主马达散热罩



Washout base set
中心滑套组件



Plastic paddle (white)
塑胶平稳翼(白色)

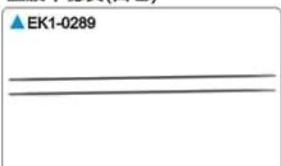

Flybar
稳定翼杆



Tail driven pedestal set
尾牙箱板



Tail rotor blade control set
尾旋翼控制组

“▲”表示Honey Bee King II 碳纤维版配件

EK1-0298



Tail rotor blade clamp set
尾旋翼夹头组

▲ EK1-0303



Main gear set
减速大齿轮组

EK1-0345



4*7*2.5mm

Bearing
轴承

▲ EK1-0560



Skid set
滑撬组

EK1-0563



8*317mm

Tail boom Set
尾管组

EK1-0566



3*7*3mm

Bearing
轴承

▲ EK1-0301



Screw & nut set
螺丝和螺母套件

▲ EK1-0582



One way drive link
单向连动件

EK1-0558



Main Frame set
机身组

▲ EK1-0561



Knighthead Set
支撑杆组

▲ EK1-0564



Belt
皮带

▲ EK1-0567

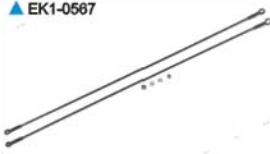

Tail push-rod set
尾拉杆组

▲ EK1-0302



Hardware Set
螺丝组

EK1-0344



Axis
轴

EK1-0559



Battery hanger set
电池架

▲ EK1-0562



Timing belt pulley
同步皮带轮组

▲ EK1-0565



Main shaft
主轴组

EK1-0568



Canopy for E016 (white)
机头罩(白色)

EK1-0568A



Canopy (yellow)
机头罩(黄色)

▲ EK2-0704



Gyro
压电式陀螺仪

▲ EK2-0851



Charger
充电器

EK1-0006



370 super motor
370强磁马达

EK1-0180



Li-Polymer battery
(11.1v 1000mAh)
锂电池 1000mAh 11.1V

▲ EK2-0406A



Transmitter 6CH CCPM TX
6通道发射机

▲ EK2-0420A



接收机 6CH 卧式
Receiver(w/o crystal)

▲ EK2-0500



8g Servo
8g舵机

EK2-0600A



Speed controller 20A
20A调速器

EK4-0004

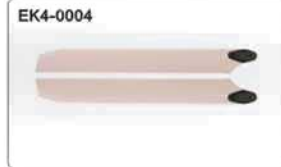

275mm Wooden blade
275mm 木质桨

▲ EK1-0218



Bearing
轴承

2*8*3mm

EK1-0502



Plastic tail blade (yellow)
塑胶尾旋翼(黄色)

EK1-0512



Plastic paddle(yellow)
塑胶平稳翼(黄色)

EK1-0500



平衡推力轴承 3*8*3.5mm
Balance trust bearing 3*8*3.5mm

EK1-0568B



Canopy 机头罩

E016/E017升级件Upgrade parts list

▲ EK4-0188



碳纤维管 Carbon fibre tail boom

▲ EK4-0185

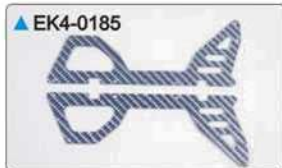

下侧板 bottom frame

▲ EK4-0184



上侧板 upper side frame

▲ EK4-0187



垂直尾Vertical Tail Blade

▲ EK4-0186



水平尾水平尾翼Horizontal Tail Blade

▲ EK5-0461



螺丝铝套 screw aluminum cannula

▲ EK4-0068Y



玻璃钢机头罩组Glass Fiber Reinforced Plastic Canopy set

▲ EK4-0068W



玻璃钢机头罩组Glass Fiber Reinforced Plastic Canopy set

▲ EK1-0597



塑胶升级组 Plastic Upgrade Set

▲ EK1-0598



拉杆头组Push-rod head set

▲ EK1-0599



底板 Main chassis

▲ EK5-0462



尾滑座组Rear slider set

▲ EK5-0460



马达固定座组 Motor Mount Set

▲ EK5-0459



连杆组 Connecting-rod

▲ EK5-0208



中心座组套装Central holder SET

▲ EK5-0201



夹头组 Collet set

▲ EK5-0202



剪形臂Washout assembly

▲ EK5-0203



倾斜盘组Swashplate set

“▲”表示Honey Bee King II 碳钎版配件
“▲” indicates the carbon fibre spare parts of Honey Bee King II



▲ EKS-0211
尾旋翼夹头组
Tail main rotor grip holder set



▲ EK5-0398
尾齿轮隔组Tail gear box



▲ EK4-0005
278*32.5*4.5mm
碳纤浆carbon fibre blade



▲ EK1-0350
调速器



▲ EK5-0004
40g 3100RPM/V
无刷马达Brushless motor



▲ EK1-0183
15C
锂聚合物电池 11.1V 1500mAh
Li-Polymer battery 11.1V 1500mAh



EK4-0052
587.5*183*118
像真机壳 红色
Scale cabin red



EK4-0050
586*190*118
像真机壳 灰色
Scale cabin Blue



EK4-0051
547*87*105
像真机壳 兰色
Scale cabin Grey



EK1-0351
9T
无刷马达齿轮Brushless motor gear



EK1-0352
10T
无刷马达齿轮Brushless motor gear



EK1-0353
11T
无刷马达齿轮Brushless motor gear

自备工具 (Facilities self-contained)



尖嘴钳 Long nosed pliers



剪刀 Scissors



EK1-2173
十字小套筒
Small Cross Sleeve



EK1-T006
3.5*120mm
十字螺丝刀
Cross Screwdriver



EK1-T000
六角螺丝刀(1.5,2.0,2.5,3.0) 4pcs
Hexangular Screwdriver set



EK1-T001
1.5mm(1.5*120) 六角螺丝刀
Hexangular Screwdriver



EK1-T002
2.0mm(2.0*120) 六角螺丝刀
Hexangular Screwdriver

一般保养方法

请定期检查: Honey Bee King II 电动遥控直升机为精密零组件构成的精细模型产品, 所以飞行者须注意确保各控制组件及机构之性能良好, 使其能发挥优异稳定的飞行特性, 如果您的维护不当, 飞行时将可能导致意外或其他损失, 建议您注意养成直升机定期检查的习惯, 以确保让您的爱机随时保持最佳性能。

主旋翼机构检查重点

- 1、主旋翼固定座: 当主旋翼运转发生异常时、飞行当中会发生明显的震动情形, 请检查主旋翼、横轴、主轴是否有变形或平衡不良, 必要时请将主旋翼头固定座更新。
- 2、主旋翼缓冲油封: 缓冲油封长期使用会发生弹性疲乏, 会影响飞行稳定性, 此时建议更新。
- 3、主旋翼夹座: 主旋翼一般飞行前虽然确认过螺距, 但实际飞行时仍需增加螺距行程才足够使用, 如飞行时升降动作迟缓情形。检查重点包含了塑胶件以及轴承、球轴承等, 塑胶件及球轴承若发现明显间隙、轴承钢珠脱落均需要更换新品。

注意:

飞行前主旋翼必须详细的做好平衡的动作, 并请修正双桨不良状况, 以提升升力效能, 注意因平衡不佳的震动将导致各零件损坏与松脱。

机身组检查重点

- 1、主轴轴承: 主轴轴承经长期重负载动作、正常飞行约100趟后必须检查各部轴承性能状况, 建议更换新品以维持运作顺畅度, 如果经常进行激烈的3D飞行或严重撞击, 建议您必须时常检查主轴轴承, 当发现主轴轴承有明显的间隙、异音或转动有明显的阻碍都必须更换新品。
- 2、单向轴承组: 单向轴承组并不经常发生损坏的情形, 但是为了保持良好顺畅的运作, 建议您使用约50趟的周期当中请拆卸下来清洁与上油。如果发生主齿轮明显异动, 请立即更换单向轴承套。
- 3、尾传动皮带: 尾传动皮带虽然采用高速传动效能纤维耐变形皮带, 但长时间使用仍然会产生延展现象, 请随时检查施以尾管重新拉伸修正调整, 以维持良好的尾舵控制机能, 如果当您发现皮带的边缘有磨损严重现象, 或是断齿的状况, 为了维护飞行的安全建议您将它更新。

控制杆组头检查重点

控制连杆、控制臂连接座、升降舵连接座组装时请特别注意各连接部位需保持顺滑且尽量减少轴向左右摇晃间隙, 此要点将严重影响飞行稳定性能。各连接杆如因坠机损坏之外、因自然磨损或是因飞行场地等恶劣因素也会发生磨损或松脱的情形, 当您发现任何连接杆发生间隙、或是轻推即可脱出, 建议您好立即更新, 以确保飞行性能与安全。

尾旋翼系统检查重点

- 1、尾齿轮组: 尾齿轮组请注意尾旋翼轴承的检查, 当您发现轴承有明显的间隙时请更新, 避免轴承咬死, 并注意尾齿轮不可将它锁死, 必须能保持顺畅运动以免发生塑胶件熔毁的情形。
- 2、尾旋翼控制滑座: 当您于草地飞行时, 请注意检查避免尾旋翼滑座是否有发生落地时卷入杂草的状况, 若有必须立即将它清除再进行下一次飞行, 否则可能会因为杂草纤维阻碍运作, 造成尾旋翼控制失常的情形, 平常保养尽量避免使用润滑油于外部机构, 避免沾染灰尘等杂物, 严重时甚至会发生其他部位轴承磨损及尾旋翼滑座无法运作的情形。
- 3、尾旋翼固定座: 飞行约50趟左右请将尾旋翼固定座拆卸下来进行清洁保养, 确认轴承间隙是否正常, 如转动不顺畅或间隙过大请更换轴承, 以确保控制系统完善。
- 4、尾旋翼: 飞行时发生触地的情形请立即检修, 若发现尾旋翼有明显的外观损伤时请立即更换, 以避免发生尾部震动并因此损伤其它零件, 确保飞行品质。

注意!

螺丝松动将导致不可预期的意外, 请务必定期检查锁固。

REGULAR MAINTENANCE:

Regular inspection: Regular maintenance is required to keep the Honey Bee King II electronic helicopter in optimal and safe flying condition. The model requires precise configuration of the components and setting to be kept by the owner. Maintain regular maintenance on the model to avoid accidents or loss, and keep the optimum performance.

MAIN ROTOR CHECKLIST:

1. Main rotor Housing: when the main rotor housing is worn or faulty, there will be obvious vibration and poor flight control. Check if the main rotor, main shaft and feathering shaft is deformed or imbalance. Replace parts as necessary to eliminate imbalance.
2. O-Rings: The O-Rings will lose their elasticity over time. This will cause excess play on rotor and cause instability. Replace as needed.
3. Main Rotor Holder: When the heli will not fly or reacts sluggishly even after checking for proper setting of pitch and throttle, The following checking is needed: Plastic parts, Bearings, Ball bearings, Rotor blades are needed to be checked. Check for excess play or gaps between the surfaces, missing or broken parts, or binding or restricted movement, it is important to check for main rotor balance before each flight. Operating the model when out of balance will cause excessive worn and premature failure of parts, possibly resulting in a dangerous situation.

The Control Arm should be checked regularly for checked, Worn, bent or binding control arms and pushrods. Smooth movement of control arms and linkages is required for stable, vibration free flight.

Attentions:

The Swashplate should be checked for excess slop in the main ball where the main shaft rides on, and slop or looseness between the plastic and metal surfaces. Swashplate wear will result in poor stability and lack of control during flight. Replace as necessary.

FUSELAGE/CHASSIS:

1. Main shaft bearing: Normal replacement interval for proper operation is 100 flights. If flying 3D or extreme aerobatics often, inspect the bearing frequently and shorten the interval as necessary.
2. One way bearing: one way bearings have longer lifetimes. Failure is not common to keep the one-way bearing in good operation, remove it and lubricate after every 50 flights. If the main driven gear is loose, you should replace the one way bearing.
3. Tail drive belt: TWF uses only the top quality stretch-proof belts. It is however impossible to prevent the belt from stretching or wearing out. Check the belt tension regularly, and check for the worn on the teeth. Replace if necessary.

LINKAGE RODS & CONNECTING PARTS.

During assembly, take special care to keep the connecting parts in smooth operation, and avoid excess play or binding. Failure to do so will result in poor stability. The linkage rods and ends will be broke and worn out due to normal usage, crashing and poor maintenance and environment. Check for wear and proper operation regularly, replace as needed.

TAIL ROTOR SYSTEM:

1. Tail rotor control set: check the tail rotor bearing regularly. If there is excess play or gaps, please replace immediately. Avoid any binding or improper contact on the tail components and bearings as this will cause excess wear and heat potentially melting or deforming the tail system.
2. Tail unit assembly: avoid flying in tall grass or weeds. If grass and weed becomes lodged in the tail rotor unit, it will interfere with the operation, as cause the helicopter to lose control. Always check for foreign objects in the tail and clean them off immediately. Avoid using lubricants on the exposed surfaces of the model as it will attract and collect dirt and debris, and cause failure.
3. Tail rotor housing: Disassemble tail rotor housing for cleaning and maintenance after every 50 flights. If the tail does not operate smoothly or shows any signs of stress or wear, please replace immediately.
4. Tail rotor: check the tail rotor blades regularly for damage, especially if the helicopter ever strikes the ground while flying, or after the hard landings. Damaged Tail Rotor blades can induce vibration.

Attentions:

The loosing screw may lead to some unexpected accidents. Make sure to check the screws regularly.

升级件的安装 Assembly process of upgraded parts

I. 主旋翼安装步骤 Assembly step for main blades.



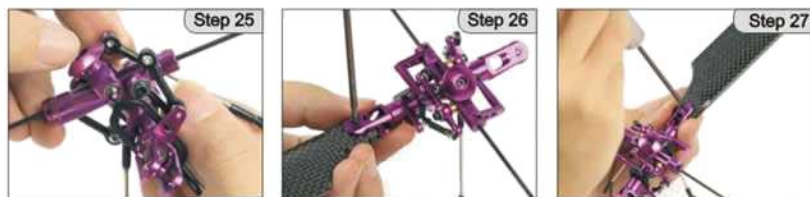

II. 尾旋翼安装步骤 Assembly step for tail rotor blades.





III. 机身安装步骤 Assembly step for body.

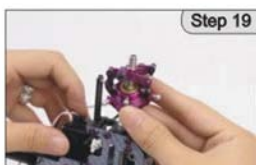
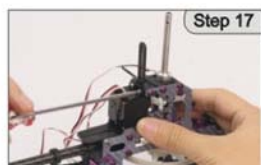
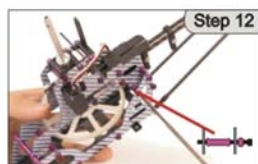
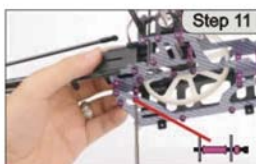
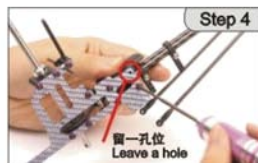
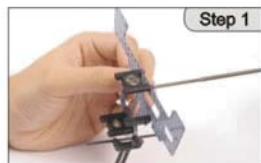

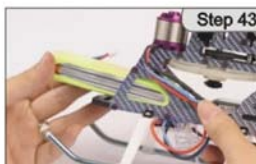
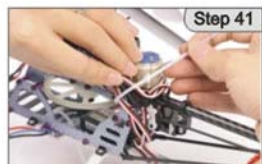
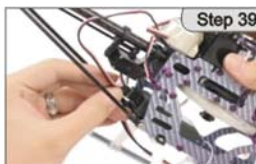
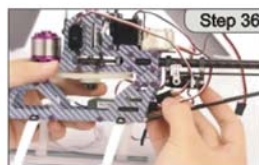
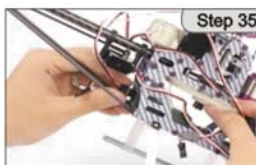
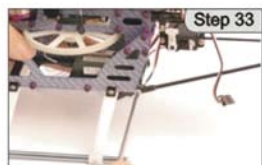
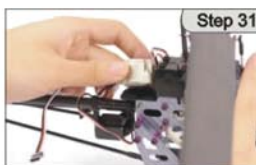
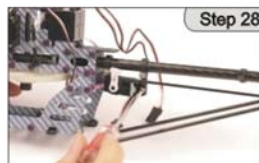
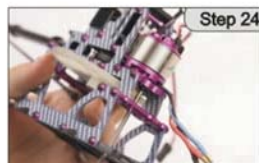
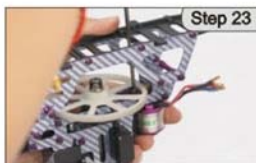

IV. 电子组装步骤 Assembly step for electronic parts.



1. 把马达固定在机身上
Fix the motor on the body



2. 将前后升降伺服器固定
Fix the front and rear ELE servos.

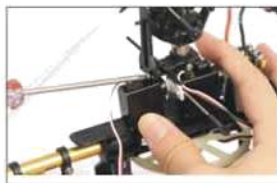

3. 将螺距伺服器固定
Fix the pitch servo.



4. 将左右副翼伺服器固定
Fix the left and right AIL servo.



5. 将调速器用双面胶粘好
Stick up the ESC with double paste.



6. 将接收机放进机身并用双面贴粘好
Put the receiver into the body and stickup with double paste.



7. 将方向伺服器固定
Fix the rudder servo.



8. 将陀螺仪固定好
Fix the GYRO.



9. 将陀螺仪和方向伺服器连接
Connect the gyro and motor.



10. 将左右副翼伺服器连接在第一通道
Connect the left & right AIL servo with Ch1



11. 将前后升降伺服器连接在第一通道
Connect the front & rear ELE servo with CH2



12. 将马达和调速器连接
Connect the motor with ESC.



13. 将调速器连接在第三通道
Connect the ESC with CH3.



14. 将陀螺仪连接在第四通道
Connect the gyro with CH4.



15. 将螺距伺服器连接在第六通道
Connect the pitch servo with CH6.

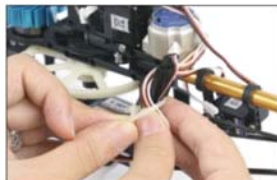

16. 将所有的线整理好
Pack up all the lines.



17. 将左右伺服器拉杆连上
Link up all the push-rods on the left right servoes.



18. 将前后升降伺服器拉杆连上
Link up all the push-rods on the front & rear servoes.



19. 将螺距伺服器拉杆连上
Link up the push-rods on the pitch servo.



20. 完成
Finished!

Honey Bee King Upgrade

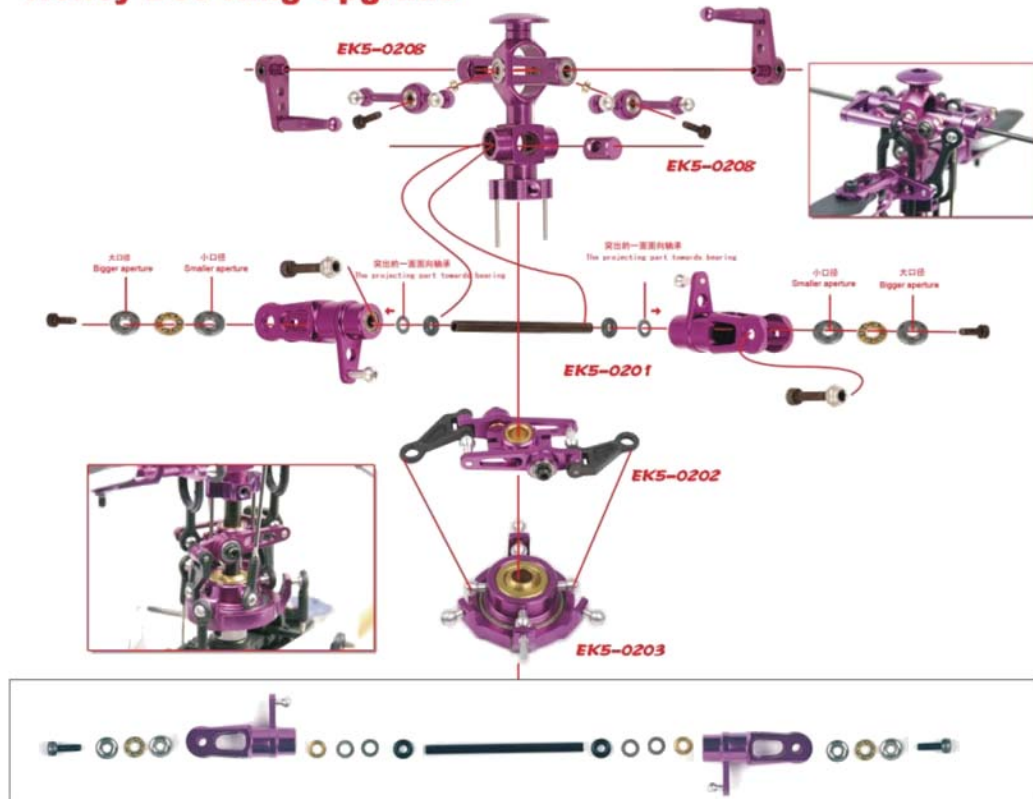



公司名称:深圳市天外飞模型贸易有限公司
 公司地址:深圳市罗湖区笋岗东路3002号万通大厦
 电话:0755-82124391 <http://www.twf-sz.com>
 传真:0755-82124390 E-mail:twf@twf-sz.com
 销售中心:深圳市罗湖区路梨园路艺展中心B座418

Company name:Shenzhen TWF Hobby Co.,Ltd
 Address:Wantong Building,NO.3002,Sungang Rd East,Luohu,Shenzhen
 Tel:0755-82124391 <http://www.twf-sz.com>
 Fax:0755-82124390 E-mail:twf@twf-sz.com
 Distribution center:NO.418,b building,Light Industrial Products City,Liyuan Rd,Luohu,Shenzhen